

PROVU PD6000 Analog Input Process Meter Instruction Manual



PROVU[®]
SERIES



Process

- 0-20 mA, 4-20 mA, 0-5 V, 1-5 V, and ± 10 V Inputs
- Multi-Pump Alternation Control
- Display One Input in Two Different Scales (e.g. Height & Volume)
- Signal Input Conditioning for Flow & Round Horizontal Tank
- 32-Point, Square Root, or Exponential Linearization
- Dual-Line Display
- NEMA 4X and IP65 Rated Front Panel
- UL Listed & CE Marked
- Display Features 0.6" & 0.46" Digits
- Six Full Digits on Each Line
- Optional Superluminous Sunlight Readable Display
- Free USB Programming Software & Cable
- 2 or 4 Relays + Isolated 4-20 mA Output Options
- USB, RS-232, & RS-485 Serial Communication Options
- External 4-Relay & Digital I/O Expansion Modules
- Universal 85-265 VAC, or 12-24 VDC Input Power Models
- Isolated 24 VDC @ 200 mA Transmitter Power Supply
- Modbus[®] RTU Communication Protocol Standard

PRECISION DIGITAL CORPORATION



233 South Street • Hopkinton MA 01748 USA
Tel (800) 343-1001 • Fax (508) 655-8990

**PRECISION
DIGITAL** 

www.predig.com

Disclaimer

The information contained in this document is subject to change without notice. Precision Digital makes no representations or warranties with respect to the contents hereof and specifically disclaims any implied warranties of merchantability or fitness for a particular purpose.

| | |
|---|--|
|  |  |
| CAUTION: <i>Read complete instructions prior to installation and operation of the meter.</i> | WARNING: <i>Risk of electric shock or personal injury.</i> |

| | |
|--|--|
|  Warning! | <i>This product is not recommended for life support applications or applications where malfunctioning could result in personal injury or property loss. Anyone using this product for such applications does so at his/her own risk. Precision Digital Corporation shall not be held liable for damages resulting from such improper use.</i> |
|--|--|

Limited Warranty

Precision Digital Corporation warrants this product against defects in material or workmanship for the specified period under “Specifications” from the date of shipment from the factory. Precision Digital’s liability under this limited warranty shall not exceed the purchase value, repair, or replacement of the defective unit.

Registered Trademarks

PROVu® and MeterView® Pro are registered trademarks of Precision Digital Corporation. Modbus® is a Registered Trademark of Schneider Automation Inc. All other trademarks mentioned in this document are the property of their respective owners.

© 2016 Precision Digital Corporation. All rights reserved.

www.predig.com

Table of Contents

| | | | |
|--|-----------|--|-----------|
| Table of Contents ----- | 3 | Relay and Alarm Operation Diagrams ----- | 27 |
| Table of Figures ----- | 4 | High Alarm Operation (Set > Reset)----- | 27 |
| Introduction ----- | 4 | Low Alarm Operation (Set < Reset)----- | 27 |
| Ordering Information ----- | 5 | High Alarm with Fail-Safe Operation (Set > Reset)--- | 28 |
| Specifications ----- | 6 | Low Alarm with Fail-Safe Operation (Set < Reset)---- | 28 |
| General ----- | 6 | Pump Alternation Control Operation----- | 29 |
| Process Input ----- | 6 | Relay Sampling Operation----- | 29 |
| Relays ----- | 7 | Signal Loss or Loop Break Relay Operation----- | 30 |
| Isolated 4-20 mA Transmitter Output ----- | 7 | Time Delay Operation----- | 30 |
| Modbus® RTU Serial Communications ----- | 7 | Relay Operation Details ----- | 31 |
| MeterView Pro ----- | 7 | Overview----- | 31 |
| Compliance Information ----- | 8 | Relays Auto Initialization----- | 31 |
| Safety ----- | 8 | Fail-Safe Operation----- | 31 |
| Electromagnetic Compatibility ----- | 8 | Front Panel LEDs----- | 31 |
| Safety Information ----- | 9 | Latching and Non-Latching Relay Operation----- | 32 |
| Installation ----- | 9 | Non-Latching Relay (RLtA)----- | 32 |
| Unpacking ----- | 9 | Non-Latching Relay (R-nn Rn)----- | 32 |
| Panel Mounting Instructions ----- | 9 | Latching Relay (LRtH)----- | 32 |
| Mounting Dimensions----- | 10 | Latching Relay (LRtLR)----- | 32 |
| Transmitter Supply Voltage Selection (P+, P-)----- | 10 | Acknowledging Relays----- | 33 |
| Connections ----- | 11 | Pump Alternation Control Applications (RLtErn)----- | 33 |
| Connectors Labeling----- | 11 | Setting Up the Interlock Relay (Force On) Feature--- | 35 |
| Power Connections----- | 11 | Scaling the 4-20 mA Analog Output (Rout)----- | 35 |
| Signal Connections----- | 12 | Reset Menu (rESEt)----- | 36 |
| Modbus RTU Serial Communications----- | 13 | Control Menu (Contrl)----- | 36 |
| Relay Connections----- | 13 | Setting Up the Password (PR55)----- | 36 |
| Switching Inductive Loads----- | 13 | Protecting or Locking the Meter----- | 36 |
| F4 Digital Input Connections----- | 14 | Making Changes to a Password Protected Meter---- | 37 |
| 4-20 mA Output Connections----- | 14 | Disabling Password Protection----- | 37 |
| Analog Output Transmitter Power Supply----- | 14 | Advanced Features Menu----- | 38 |
| External Relays & Digital I/O Connections----- | 15 | Advanced Features Menu & Display Messages----- | 38 |
| Interlock Relay Feature----- | 15 | Noise Filter (FiltEr)----- | 39 |
| Setup and Programming ----- | 16 | Noise Filter Bypass (bYP55)----- | 39 |
| Overview ----- | 16 | Rounding Feature (round)----- | 39 |
| Front Panel Buttons and Status LED Indicators ----- | 16 | Modbus RTU Serial Communications (SEr RL)----- | 40 |
| MeterView® Pro Software ----- | 17 | Select Menu (SELEct)----- | 40 |
| MeterView Pro Installation----- | 17 | Signal Input Conditioning (FunctEn)----- | 41 |
| Display Functions & Messages ----- | 18 | Low-Flow Cutoff (LutOFF)----- | 42 |
| Main Menu ----- | 19 | Analog Output Programming (RoutPr)----- | 42 |
| Setting Numeric Values ----- | 19 | Programmable Function Keys User Menu (u5Er)----- | 42 |
| Setting Up the Meter (SEtUP)----- | 20 | Tare (tRrE)----- | 43 |
| Setting the Input Signal (InPUt)----- | 20 | Internal Source Calibration (iLR)----- | 44 |
| Setting the Input Units or Custom Tags (unIt5)----- | 21 | Meter Operation ----- | 45 |
| Setting the Decimal Point (dEc Pt)----- | 21 | Front Panel Buttons Operation ----- | 45 |
| Programming the Meter (PrG)----- | 22 | Function Keys Operation ----- | 45 |
| Setting the Display Parameter & Intensity (d5PLR4)--- | 25 | F4 Operation ----- | 45 |
| Setting the Relay Operation (rELAY)----- | 26 | Maximum/Minimum Readings ----- | 45 |
| Setting the Relay Action----- | 26 | Troubleshooting ----- | 46 |
| Programming Set and Reset Points----- | 26 | Diagnostics Menu (dRG)----- | 46 |
| Setting Fail-Safe Operation----- | 27 | Determining Software Version----- | 46 |
| Programming Time Delay----- | 27 | Reset Meter to Factory Defaults ----- | 46 |
| Relay Action for Loss of 4-20 mA Input (Loop Break) 27 | | Factory Defaults & User Settings----- | 47 |
| | | Troubleshooting Tips ----- | 48 |
| | | EU Declaration of Conformity ----- | 49 |

Table of Figures

| | | | |
|--|----|---|----|
| Figure 1. 1/8 DIN Panel Cutout Dimensions | 9 | Figure 11. Relay Connections..... | 13 |
| Figure 2. Panel Mounting Details | 9 | Figure 12. AC and DC Loads Protection..... | 13 |
| Figure 3. Meter Dimensions - Side View | 10 | Figure 13. Low Voltage DC Loads Protection | 13 |
| Figure 4. Meter Dimensions - Top View | 10 | Figure 14. F4 Digital Input Connections..... | 14 |
| Figure 5. Transmitter Supply Voltage Selection | 10 | Figure 15. 4-20 mA Output Connections..... | 14 |
| Figure 6. Connector Labeling for Fully Loaded PD6000 | 11 | Figure 16. Expansion Modules & DIN Rail Mounting Kit | 15 |
| Figure 7. Power Connections | 11 | Figure 17. External Relays Module Connections | 15 |
| Figure 8. Transmitters Powered by Internal Supply | 12 | Figure 18. Digital I/O Module Connections | 15 |
| Figure 9. Transmitter Powered by Ext. Supply or Self- Powered | 12 | Figure 19. Interlock Connections | 15 |
| Figure 10. Voltage Input Connections | 12 | Figure 20. Acknowledge Relays w/Function Key or Digital Input..... | 33 |

Introduction

The PROVu® PD6000 is a multi-purpose, easy-to-use digital process meter ideal for level, flow rate, temperature, or pressure transmitter applications. Its superluminous LED digits make it easily readable in smoke, dust, fog, and, with the optional SunBright® display, even direct sunlight. It accepts current and voltage signals (e.g. 4-20 mA, 0-10 V). Three of the front panel buttons can be custom-programmed for a specific operation. The analog input can be scaled to display the process in two different scales; for example, the main display could indicate level in feet and the second display could indicate the volume in gallons.

The basic model includes an isolated 24 VDC transmitter power supply that can be used to power the input transmitter or other devices. An additional isolated 24 VDC power supply is included with the 4-20 mA output option. A digital input is standard.

A fully loaded PD6000 meter has the following: four SPDT relays, 4-20 mA output, and two 24 VDC power supplies. The PD6000 capabilities may be enhanced by adding the following external expansion modules: four SPST relays (creating an eight-relay process meter), two digital I/O modules with four inputs and four outputs each, and USB, RS-232 or RS-485 communication adapters.

The eight relays can be used for alarm indication or process control applications such as pump alternation control. The 4-20 mA isolated output, Modbus RTU serial communications, and digital I/O options make the PD6000 an excellent addition to any system.

Ordering Information

Standard Models

| 85-265 VAC Model | 12-24 VDC Model | Options Installed |
|------------------|-----------------|-------------------------------------|
| PD6000-6R0 | PD6000-7R0 | No options |
| PD6000-6R2 | PD6000-7R2 | 2 relays (PD1102*) |
| PD6000-6R3 | PD6000-7R3 | 4-20 mA output (PD1103*) |
| PD6000-6R4 | PD6000-7R4 | 4 relays (PD1104*) |
| PD6000-6R5 | PD6000-7R5 | 2 relays & 4-20 mA output (PD1105*) |
| PD6000-6R7 | PD6000-7R7 | 4 relays & 4-20 mA output (PD1107*) |

*Model number for replacement option card.

SunBright Display Models

| 85-265 VAC Model | 12-24 VDC Model | Options Installed |
|------------------|-----------------|-------------------------------------|
| PD6000-6H0 | PD6000-7H0 | No options |
| PD6000-6H2 | PD6000-7H2 | 2 relays (PD1102*) |
| PD6000-6H3 | PD6000-7H3 | 4-20 mA output (PD1103*) |
| PD6000-6H4 | PD6000-7H4 | 4 relays (PD1104*) |
| PD6000-6H5 | PD6000-7H5 | 2 relays & 4-20 mA output (PD1105*) |
| PD6000-6H7 | PD6000-7H7 | 4 relays & 4-20 mA output (PD1107*) |

*Model number for replacement option card.

Accessories

| Model | Description |
|-----------|---|
| PDA1002 | DIN rail mounting kit for two expansion modules |
| PDA1004 | 4 SPST (Form A) relays |
| PDA1044 | 4 digital inputs & 4 digital outputs (2 may be connected) |
| PDA1232 | RS-232 serial adapter |
| PDA1485 | RS-485 serial adapter |
| PDA7485-I | RS-232 to RS-422/485 isolated converter |
| PDA7485-N | RS-232 to RS-422/485 non-isolated converter |
| PDA8232-N | USB to RS-232 non-isolated converter |
| PDA8485-I | USB to RS-422/485 isolated converter |
| PDA8485-N | USB to RS-422/485 non-isolated converter |
| PDX6901 | Suppressor (snubber): 0.01 μ F/470 Ω , 250 VAC |

Enclosures

| Model | Description |
|---------|-----------------------------------|
| PDA2811 | 1 Meter Plastic NEMA 4X Enclosure |
| PDA2812 | 2 Meter Plastic NEMA 4X Enclosure |

Specifications

Except where noted all specifications apply to operation at +25°C.

General

| | |
|--|---|
| Display | Line 1: 0.60" (15 mm) high, red LEDs Line 2: 0.46" (12 mm) high, red LEDs 6 digits each (-99999 to 999999), with lead zero blanking |
| Display Intensity | Eight user selectable intensity levels |
| Display Update Rate | 5/second (200 ms) |
| Overrange | Display flashes 999999 |
| Underrange | Display flashes -99999 |
| Display Assignment | Display lines 1 and 2 may be assigned to PV1, PV2, PCT, d r-u, d gross, d nt-g, max/min, max & min, set points, units (display line 2 only), or Modbus input. |
| Programming Methods | Four front panel buttons, digital inputs, PC and MeterView Pro software, or Modbus registers. |
| Noise Filter | Programmable from 2 to 199 (0 will disable filter) |
| Filter Bypass | Programmable from 0.1 to 99.9% of calibrated span |
| Recalibration | All ranges are calibrated at the factory. Recalibration is recommended at least every 12 months. |
| Max/Min Display | Max/min readings reached by the process are stored until reset by the user or until power to the meter is turned off. |
| Password | Three programmable passwords restrict modification of programmed settings. Pass 1: Allows use of function keys and digital inputs Pass 2: Allows use of function keys, digital inputs and editing set/reset points Pass 3: Restricts all programming, function keys, and digital inputs. |
| Power Options | 85-265 VAC 50/60 Hz, 90-265 VDC, 20 W max or 12-24 VDC ± 10%, 15 W max Powered over USB for configuration only. |
| Isolated Transmitter Power Supply | Terminals P+ & P-: 24 VDC ± 10%. 12-24 VDC powered models selectable for 24, 10, or 5 VDC supply (internal jumper J4). 85-265 VAC models rated @ 200 mA max, 12-24 VDC powered models rated @ 100 mA max, @ 50 mA max for 5 or 10 VDC supply. |
| Non-Volatile Memory | All programmed settings are stored in non-volatile memory for a minimum of ten years if power is lost. |
| Fuse | Required external fuse: UL Recognized, 5 A max, slow blow; up to 6 meters may share one 5 A fuse |
| Normal Mode Rejection | Greater than 60 dB at 50/60 Hz |
| Isolation | 4 kV input/output-to-power line 500 V input-to-output or output-to-P+ supply |
| Overvoltage Category | Installation Overvoltage Category II: Local level with smaller transient overvoltages than Installation Overvoltage Category III. |

| | |
|---------------------------|---|
| Environmental | Operating temperature range: -40 to 65°C Storage temperature range: -40 to 85°C Relative humidity: 0 to 90% non-condensing |
| Connections | Removable screw terminal blocks accept 12 to 22 AWG wire, RJ45 for external relays, digital I/O, and serial communication adapters. |
| Enclosure | 1/8 DIN, high impact plastic, UL 94V-0, color: black |
| Mounting | 1/8 DIN panel cutout required: 3.622" x 1.772" (92 mm x 45 mm) Two panel mounting bracket assemblies are provided. |
| Tightening Torque | Screw terminal connectors: 5 lb-in (0.56 Nm) |
| Overall Dimensions | 4.68" x 2.45" x 5.64" (119 mm x 62 mm x 143 mm) (W x H x D) |
| Weight | 9.5 oz (269 g) |
| Warranty | 3 years parts & labor |

Process Input

| Inputs | Field selectable: 0-20, 4-20 mA, ±10 V (0-5, 1-5, 0-10 V), Modbus PV (Slave) | | | | | | |
|----------------------------------|---|-------------|--------------------------------|---------|---------|-------|--------|
| Accuracy | ±0.03% of calibrated span ±1 count, square root & programmable exponent accuracy range: 10-100% of calibrated span | | | | | | |
| Temperature Drift | 0.005% of calibrated span/°C max from 0 to 65°C ambient, 0.01% of calibrated span/°C max from -40 to 0°C ambient | | | | | | |
| Signal Input Conditioning | Linear, square root, programmable exponent, or round horizontal tank volume calculation | | | | | | |
| Multi-Point Linearization | 2 to 32 points for PV or PV1 2 to 8 points for PV2 (Dual-scale Level feature) | | | | | | |
| Programmable Exponent | 1.0001 to 2.9999 | | | | | | |
| Round H Tank | Diameter & Length: 999.999 inch or cm calculates volume in gallons or liters respectively. | | | | | | |
| Low-Flow Cutoff | 0-999999 (0 disables cutoff function) | | | | | | |
| Decimal Point | Up to five decimal places or none: <i>d.ddd</i> , <i>ddd</i> , <i>ddd.</i> , <i>ddd.</i> , <i>ddd.</i> , or <i>ddd</i> | | | | | | |
| Calibration Range | <table border="1"> <tr> <th>Input Range</th> <th>Minimum Span Input 1 & Input 2</th> </tr> <tr> <td>4-20 mA</td> <td>0.15 mA</td> </tr> <tr> <td>±10 V</td> <td>0.01 V</td> </tr> </table> <p>An error message will appear if the input 1 and input 2 signals are too close together.</p> | Input Range | Minimum Span Input 1 & Input 2 | 4-20 mA | 0.15 mA | ±10 V | 0.01 V |
| Input Range | Minimum Span Input 1 & Input 2 | | | | | | |
| 4-20 mA | 0.15 mA | | | | | | |
| ±10 V | 0.01 V | | | | | | |
| Input Impedance | Voltage ranges: greater than 500 kΩ Current ranges: 50 - 100 Ω (depending on resettable fuse impedance) | | | | | | |
| Input Overload | Current input protected by resettable fuse, 30 VDC max. Fuse resets automatically after fault is removed. | | | | | | |
| F4 Digital Input Contacts | 3.3 VDC on contact. Connect normally open contacts across F4 to COM. | | | | | | |

| | |
|--------------------------------------|--|
| F4 Digital Input Logic Levels | Logic High: 3 to 5 VDC Logic Low: 0 to 1.25 VDC |
|--------------------------------------|--|

Relays

| | |
|----------------------------|--|
| Rating | 2 or 4 SPDT (Form C) internal and/or 4 SPST (Form A) external; rated 3 A @ 30 VDC and 125/250 VAC resistive load; 1/14 HP (\approx 50 W) @ 125/250 VAC for inductive loads |
| Noise Suppression | Noise suppression is recommended for each relay contact switching inductive loads; see page 13 for details. |
| Deadband | 0-100% of span, user programmable |
| High or Low Alarm | User may program any alarm for high or low trip point. Unused alarm LEDs and relays may be disabled (turn off). |
| Relay Operation | Automatic (non-latching) and/or manual reset Latching (requires manual acknowledge) with/without clear Pump alternation control (2 to 8 relays) Sampling (based on time) Off (disable unused relays and enable Interlock feature) Manual on/off control mode |
| Relay Reset | User selectable via front panel buttons or digital inputs <ol style="list-style-type: none"> Automatic reset only (non-latching), when the input passes the reset point. Automatic + manual reset at any time (non-latching) Manual reset only, at any time (latching) Manual reset only after alarm condition has cleared (latching) <p><i>Note: Front panel button or digital input may be assigned to acknowledge relays programmed for manual reset.</i></p> |
| Time Delay | 0 to 999.9 seconds, on & off relay time delays Programmable and independent for each relay |
| Fail-Safe Operation | Programmable and independent for each relay. <i>Note: Relay coil is energized in non-alarm condition. In case of power failure, relay will go to alarm state.</i> |
| Auto Initialization | When power is applied to the meter, relays will reflect the state of the input to the meter. |

Isolated 4-20 mA Transmitter Output

| | | | |
|--|---|--------------|---------------|
| Output Source | Process variable (PV), max, min, set points 1-8, Modbus input, or manual control mode | | |
| Scaling Range | 1.000 to 23.000 mA for any display range | | |
| Calibration | Factory calibrated: 4.000 to 20.000 = 4-20 mA output | | |
| Analog Out Programming | 23.000 mA maximum for all parameters: Overrange, underrange, max, min, and break | | |
| Accuracy | \pm 0.1% of span \pm 0.004 mA | | |
| Temperature Drift | 0.4 μ A/ $^{\circ}$ C max from 0 to 65 $^{\circ}$ C ambient, 0.8 μ A/ $^{\circ}$ C max from -40 to 0 $^{\circ}$ C ambient <i>Note: Analog output drift is separate from input drift.</i> | | |
| Isolated Transmitter Power Supply | Terminals I+ & R: 24 VDC \pm 10%. May be used to power the 4-20 mA output or other devices. Refer to Transmitter Supply Voltage Selection (P+, P-) on page 10. All models rated @ 40 mA max. | | |
| External Loop Power Supply | 35 VDC maximum | | |
| Output Loop Resistance | Power supply | Minimum | Maximum |
| | 24 VDC | 10 Ω | 700 Ω |
| | 35 VDC (external) | 100 Ω | 1200 Ω |

Modbus[®] RTU Serial Communications

| | |
|-----------------------------|--|
| Slave Id | 1 – 247 (Meter address) |
| Baud Rate | 300 – 19,200 bps |
| Transmit Time Delay | Programmable between 0 and 199 ms |
| Data | 8 bit (1 start bit, 1 or 2 stop bits) |
| Parity | Even, Odd, or None with 1 or 2 stop bits |
| Byte-To-Byte Timeout | 0.01 – 2.54 second |
| Turn Around Delay | Less than 2 ms (fixed) |

Note: Refer to the PROVu[®] Modbus Register Tables located at www.predig.com for details.

MeterView Pro

| | |
|----------------------------|---|
| System Requirements | Microsoft [®] Windows [®] XP/Vista/7/8/10 |
| Communications | USB 2.0 (Standard USB A to Micro USB B) |
| Configuration | Configure meters one at a time |

Compliance Information

Safety

| | |
|------------------------------|---|
| UL & C-UL Listed | USA & Canada UL 508 Industrial Control Equipment |
| UL File Number | E160849 |
| Front Panel | UL Type 4X, NEMA 4X, IP65; panel gasket provided |
| Low Voltage Directive | EN 61010-1:2010 Safety requirements for measurement, control, and laboratory use |

Electromagnetic Compatibility

| | |
|--------------------------------|--|
| Emissions | EN 55022:2010 Class A ITE emissions requirements |
| Radiated Emissions | Class A |
| AC Mains Conducted Emissions | Class A |
| Immunity | EN 61326-1:2013 Measurement, control, and laboratory equipment EN 61000-6-2:2005 EMC heavy industrial generic immunity standard |
| RFI - Amplitude Modulated | 80 -1000 MHz 10 V/m 80% AM (1 kHz) 1.4 - 2.0 GHz 3 V/m 80% AM (1 kHz) 2.0 - 2.7 GHz 1 V/m 80% AM (1 kHz) |
| Electrical Fast Transients | ±2kV AC mains, ±1kV other |
| Electrostatic Discharge | ±4kV contact, ±8kV air |
| RFI - Conducted | 10V, 0.15-80 MHz, 1kHz 80% AM |
| AC Surge | ±2kV Common, ±1kV Differential |
| Surge | 1KV (CM) |
| Power-Frequency Magnetic Field | 30 A/m 70%V for 0.5 period |
| Voltage Dips | 40%V for 5 & 50 periods 70%V for 25 periods |
| Voltage Interruptions | <5%V for 250 periods |

Note:

Testing was conducted on PD6000 meters installed through the covers of grounded metal enclosures with cable shields grounded at the point of entry representing installations designed to optimize EMC performance.

Declaration of Conformity available at www.predig.com

Safety Information

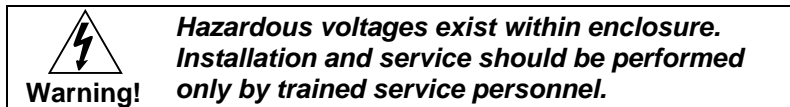
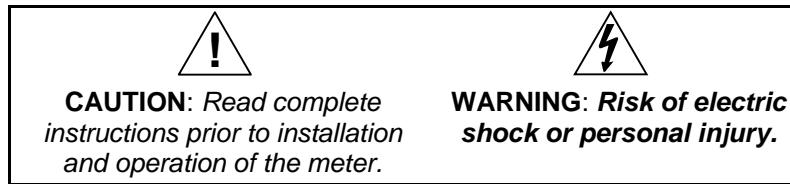

Installation

There is no need to remove the meter from its case to complete the installation, wiring, and setup of the meter for most applications.

Instructions are provided for changing the transmitter power supply to output 5 or 10 VDC instead of 24 VDC, see page 10.

Unpacking

Remove the meter from box. Inspect the packaging and contents for damage. Report damages, if any, to the carrier.

If any part is missing or the meter malfunctions, please contact your supplier or the factory for assistance.

Panel Mounting Instructions

- Prepare a standard 1/8 DIN panel cutout – 3.622" x 1.772" (92 mm x 45 mm). Refer to Figure 1 below, for more details.
- Clearance: allow at least 6.0" (152 mm) behind the panel for wiring.
- Panel thickness: 0.04" - 0.25" (1.0 mm - 6.4 mm).
Recommended minimum panel thickness to maintain Type 4X rating: 0.06" (1.5 mm) steel panel, 0.16" (4.1 mm) plastic panel.
- Remove the two mounting brackets provided with the meter (back-off the two screws so that there is ¼" (6.4 mm) or less through the bracket. Slide the bracket toward the front of the case and remove).
- Insert meter into the panel cutout.
- Install mounting brackets and tighten the screws against the panel. To achieve a proper seal, tighten the mounting bracket screws evenly until meter is snug to the panel along its short side. **DO NOT OVER TIGHTEN**, as the rear of the panel may be damaged.

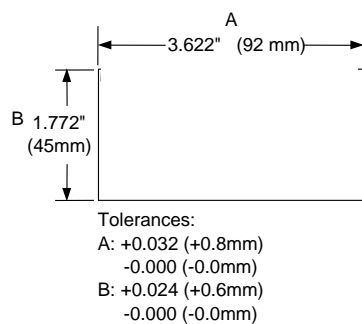

Figure 1. 1/8 DIN Panel Cutout Dimensions

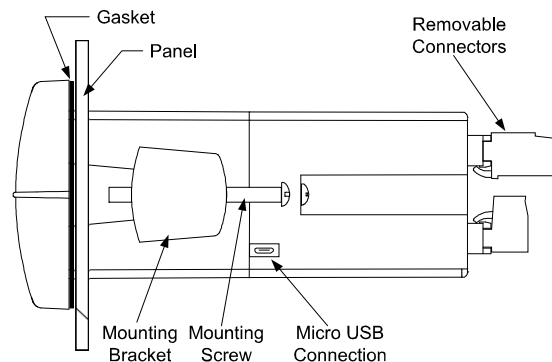

Figure 2. Panel Mounting Details

Mounting Dimensions

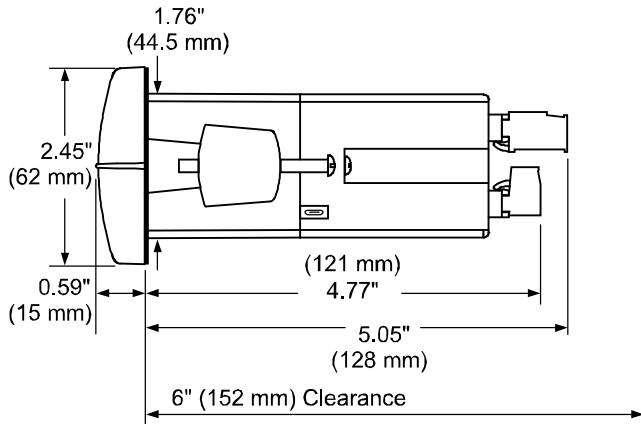

Figure 3. Meter Dimensions - Side View

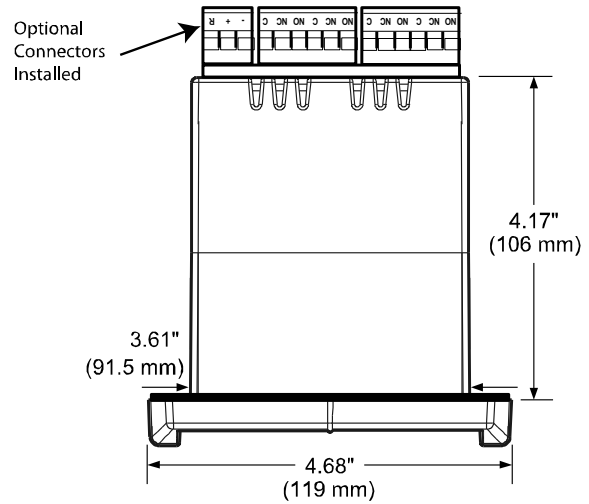

Figure 4. Meter Dimensions - Top View

Transmitter Supply Voltage Selection (P+, P-)

All meters, including models equipped with the 12-24 VDC power option, are shipped from the factory configured to provide 24 VDC power for the transmitter or sensor.

If the transmitter requires 5 or 10 VDC excitation, the internal jumper J4 must be configured accordingly.

To access the voltage selection jumper:

1. Remove all the wiring connectors.
2. Unscrew the back cover.
3. Slide out the back cover by about 1 inch.
4. Configure the J4 jumper, located behind the input signal connector, for the desired excitation voltage as shown.

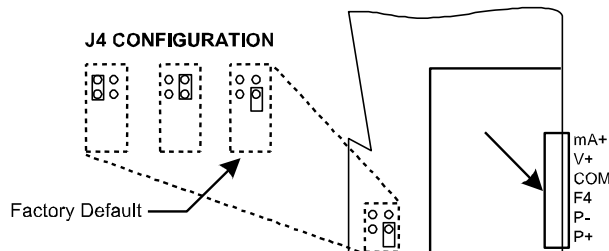



Figure 5. Transmitter Supply Voltage Selection

Connections

All connections are made to removable screw terminal connectors located at the rear of the meter.



Use copper wire with 60°C or 60/75°C insulation for all line voltage connections. Observe all safety regulations. Electrical wiring should be performed in accordance with all applicable national, state, and local codes to prevent damage to the meter and ensure personnel safety.

Connectors Labeling

The connectors' label, affixed to the meter, shows the location of all connectors available with requested configuration.



Warning! *Do not connect any equipment other than Precision Digital's expansion modules, cables, or meters to the RJ45 M-LINK connector. Otherwise damage will occur to the equipment and the meter.*

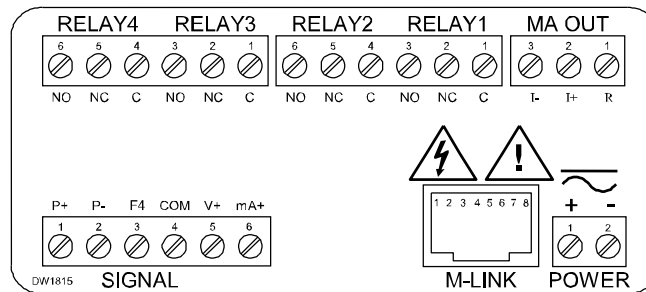

Figure 6. Connector Labeling for Fully Loaded PD6000

Power Connections

Power connections are made to a two-terminal connector labeled POWER on Figure 6 on page 11. The meter will operate regardless of DC polarity connection. The + and - symbols are only a suggested wiring convention.

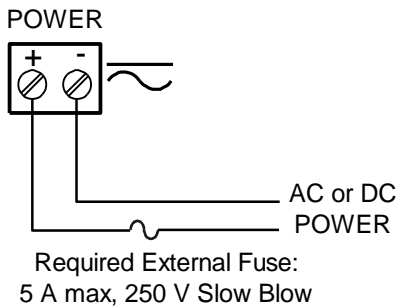

Figure 7. Power Connections

Signal Connections

Signal connections are made to a six-terminal connector labeled SIGNAL on Figure 6. The COM (common) terminal is the return for the 4-20 mA and the ± 10 V input signals.

Current (mA) Connections

The following figures show examples of current connections.

There are no switches or jumpers to set up for current inputs. Setup and programming is performed through the front panel buttons.

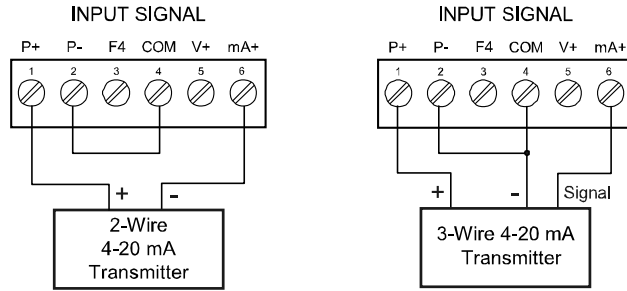

Figure 8. Transmitters Powered by Internal Supply

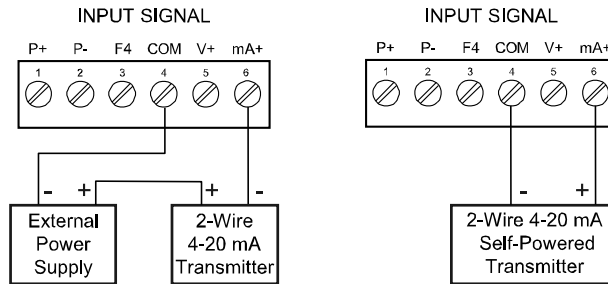

Figure 9. Transmitter Powered by Ext. Supply or Self-Powered

The current input is protected against current overload by a resettable fuse. The display may or may not show a fault condition depending on the nature of the overload.

The fuse limits the current to a safe level when it detects a fault condition, and automatically resets itself when the fault condition is removed.

Voltage (V) Connections

The following figures show examples of voltage connections.

There are no switches or jumpers to set up for voltage inputs. Setup and programming is performed through the front panel buttons.

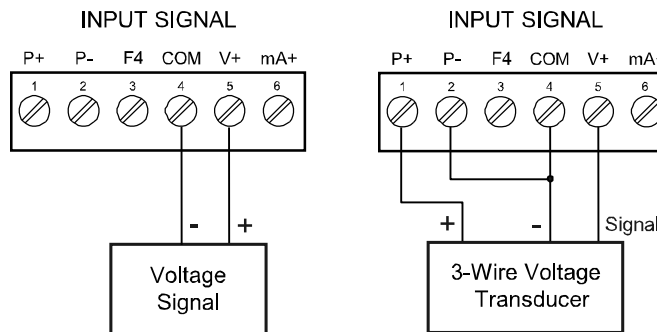

Figure 10. Voltage Input Connections

The meter is capable of accepting any voltage from -10 VDC to +10 VDC.

Modbus RTU Serial Communications

Serial communications connection is made to an RJ45 connector labeled M-LINK on Figure 6. For interfacing to the PROVu®, use the PDA1232 for RS-232 or the PDA1485 for RS-485. The same port is used for interfacing with all expansion modules (e.g. external relays, digital I/O).

Relay Connections

Relay connections are made to two six-terminal connectors labeled RELAY1 – RELAY4 on Figure 6. Each relay's C terminal is common only to the normally open (NO) and normally closed (NC) contacts of the corresponding relay. The relays' C terminals should not be confused with the COM (common) terminal of the INPUT SIGNAL connector.

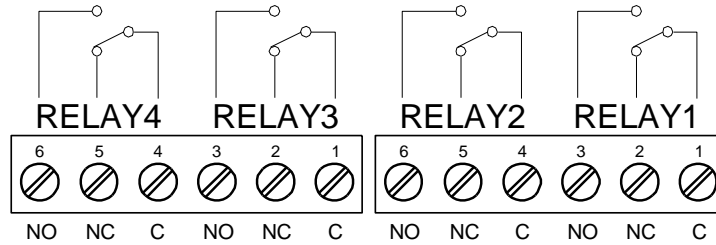

Figure 11. Relay Connections

Switching Inductive Loads

The use of suppressors (snubbers) is strongly recommended when switching inductive loads to prevent disrupting the microprocessor's operation. The suppressors also prolong the life of the relay contacts. Suppression can be obtained with resistor-capacitor (RC) networks assembled by the user or purchased as complete assemblies. Refer to the following circuits for RC network assembly and installation:

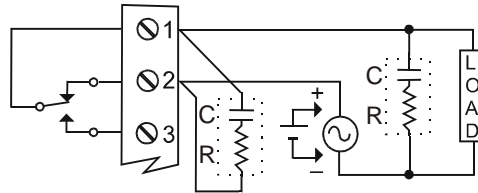

Figure 12. AC and DC Loads Protection

Choose R and C as follows:

- R: 0.5 to 1 Ω for each volt across the contacts
- C: 0.5 to 1 μF for each amp through closed contacts

Notes:

1. Use capacitors rated for 250 VAC.
2. RC networks may affect load release time of solenoid loads. Check to confirm proper operation.
3. Install the RC network at the meter's relay screw terminals. An RC network may also be installed across the load. Experiment for best results.

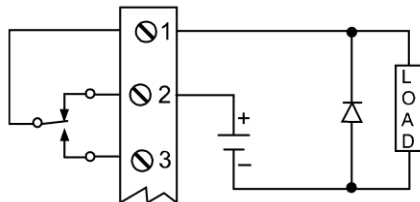

Use a diode with a reverse breakdown voltage two to three times the circuit voltage and forward current at least as large as the load current.

Figure 13. Low Voltage DC Loads Protection

RC Networks Available from Precision Digital

RC networks are available from Precision Digital and should be applied to each relay contact switching an inductive load. Part number: PDX6901.

Note: Relays are de-rated to 1/14th HP (50 watts) with an inductive load.

F4 Digital Input Connections

A digital input, F4, is standard on the meter. This digital input is connected with a normally open contact across F4 and COM, or with an active low signal applied to F4.

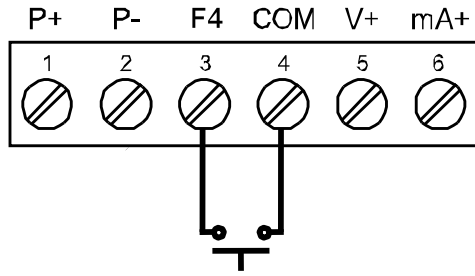

Figure 14. F4 Digital Input Connections

4-20 mA Output Connections

Connections for the 4-20 mA transmitter output are made to the connector terminals labeled MA OUT. The 4-20 mA output may be powered internally or from an external power supply.

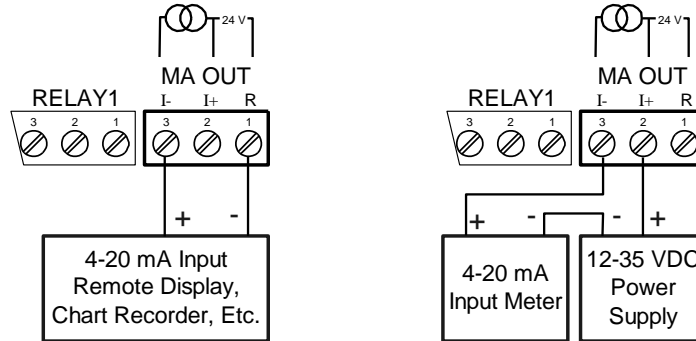

Figure 15. 4-20 mA Output Connections

Analog Output Transmitter Power Supply

The internal 24 VDC power supply powering the analog output may be used to power other devices, if the analog output is not used. The I+ terminal is the +24 V and the R terminal is the return.

External Relays & Digital I/O Connections

The relay and the digital I/O expansion modules PDA1004 & PDA1044 are connected to the meter using a CAT5 cable provided with each module. The two RJ45 connectors on the expansion modules are identical and interchangeable; they are used to connect additional modules to the system.

Note: The jumper located between the RJ45 connectors of the PDA1044 must be removed on the second digital I/O module in order for the system to recognize it as module #2.



Warning! *Do not connect or disconnect the expansion modules with the power on!*

More detailed instructions are provided with each optional expansion module.

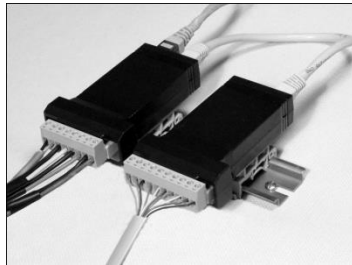

Figure 16. Expansion Modules & DIN Rail Mounting Kit

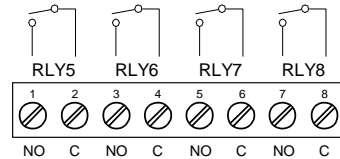

Figure 17. External Relays Module Connections

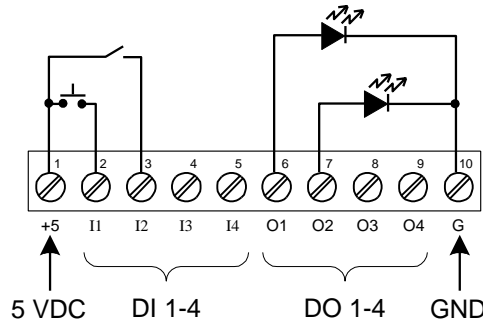

Figure 18. Digital I/O Module Connections

Interlock Relay Feature

As the name implies, the interlock relay feature reassigns one, or more, alarm/control relays for use as interlock relay(s). Interlock contact(s) are wired to digital input(s) and trigger the interlock relay. This feature is enabled by configuring the relay, and relative digital input(s) (see page 35).

In one example, dry interlock contacts are connected in series to one digital input which will be used to force on (energize) the assigned interlock power relay when all interlock contacts are closed (safe). The interlock relay front panel LED flashes when locked out. The interlock relay would be wired in-series with the load (N/O contact). See below.

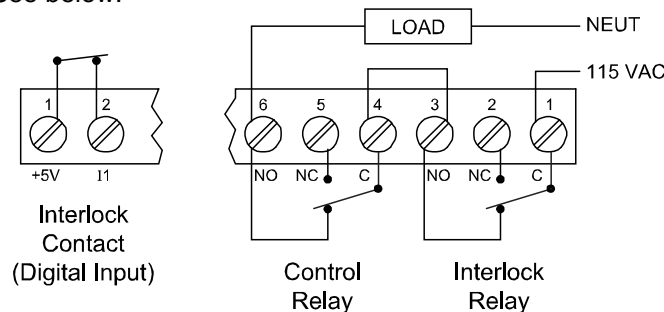

Figure 19. Interlock Connections

Setup and Programming

The meter is factory calibrated prior to shipment to read in milliamps and volts depending on the input selection. The calibration equipment is certified to NIST standards.

Overview





There are no jumpers to set for the meter input selection.

Setup and programming is done through the front panel buttons.

After power and input signal connections have been completed and verified, apply power to the meter.

Front Panel Buttons and Status LED Indicators



| Button Symbol | Description | LED | Status |
|---|-----------------------|---|--|
|  | Menu | 1-8 | Alarm 1-8 indicator |
|  | Right arrow/F1 | 1-8 M | Flashing: Relay in manual control mode |
|  | Up arrow/F2 | T | Flashing: Tare |
|  | Enter/F3 | 1-8 | Flashing: Relay interlock switch open |
| <p><i>Note:</i> F4 is a digital input. Alarms 5-8 are enabled when relay expansion module is installed.</p> | | <p><i>Note:</i> LEDs for relays in manual mode flash with the "M" LED every 10 seconds. "M" flashing by itself indicates Aout – manual control is used.</p> | |

- Press the Menu button to enter or exit the Programming Mode at any time.
- Press the Right arrow button to move to the next digit during digit or decimal point programming.
- Press or hold the Up arrow button to scroll through the menus, decimal point, or to increment the value of a digit.
- Press the Enter button to access a menu or to accept a setting.
- Press and hold the Menu button for three seconds to access the advanced features of the meter.

MeterView® Pro Software

The meter can also be programmed using the PC-based MeterView Pro software included with the meter. This software can be installed on any Microsoft® Windows® (XP/Vista/7/8/10) computer by connecting the meter's onboard USB. The meter is powered by the USB connection, so there is no need to wire anything prior to programming the meter, though USB is intended only for meter configuration.

MeterView Pro Installation

1. Connect one end of the provided USB cable to the meter and the other end to the computer. The computer will automatically install the driver software it needs to talk to the meter.

Only one meter may be connected at a time.
Attaching multiple meters will cause a conflict with the meter software.

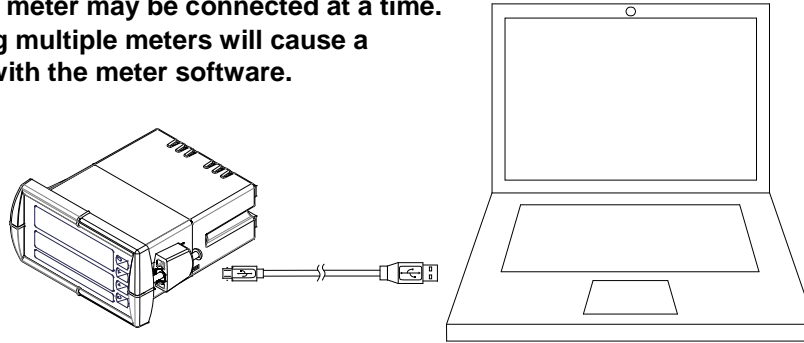

2. Once the driver is installed, an AutoPlay dialog should appear for the drive "MAINSTAL." Click "Open folder to view files." If the computer does not display an AutoPlay dialog for the drive "MAINSTAL," you should open My Computer and double-click on the drive labeled "MAINSTAL."
3. Double-click on the file named "MAStart." The program will open a few windows and install two programs on your computer. Simply follow the onscreen instructions until you see one of the dialogs below. If you receive a "User Account Control" warning, click "Yes."
4. If there is an update available, click the "Update" button to install the new version. Otherwise, click "Configure" to begin programming your meter.

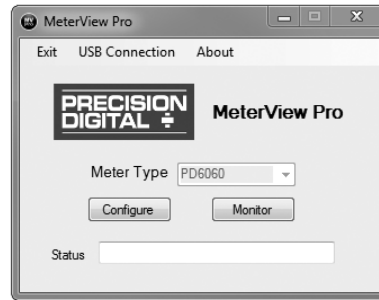
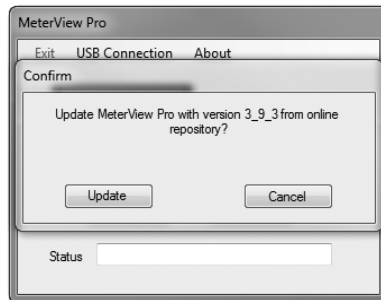
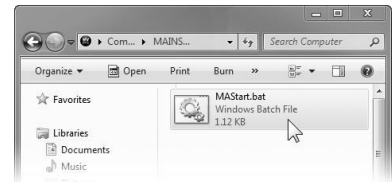

Note: If you decide to update your MeterView Pro software, once the installation has completed, you will be asked if you want to update the setup files located on the meter itself. This way, you will always have the most current version on the meter for future installs.



Do not unplug the meter while the new installation files are being written to it. The meter will display μ sr tE during the process and you will receive an onscreen notification once the process is complete.

Data logging for one meter at a time is available with MeterView Pro software. More advanced data acquisition may be accomplished by using any Modbus RTU compliant software. Additional information regarding configuration and monitoring of the meter using MeterView Pro software is available online. Go to www.predig.com/meterview-pro.

Display Functions & Messages

The meter displays various functions and messages during setup, programming, and operation. The following table shows the main menu functions and messages in the order they appear in the menu.

| Display | Parameter | Action/Setting Description | Display | Parameter | Action/Setting Description |
|---------|-------------------|---|---------|------------------|---|
| ሪፔት | Setup | Enter Setup menu | ፎርገት | Latching-cleared | Set relay for latching operation with manual reset only after alarm condition has cleared |
| ከፎርገት | Input | Enter Input selection menu | ፎርገት | Alternate | Set relay for pump alternation control |
| ፎርገት | 4-20 mA | Set meter for 4-20 mA input | ፎርገት | Sampling | Set relay for sampling operation |
| ፎርገት | 0-10 VDC | Set meter for ±10 VDC input | ፎርገት | Off | Disable relay and front panel status LED (Select Off to enable Interlock feature) |
| ፎርገት | Dual-scale | Press Enter to select dual-scale display for some level applications (Select Yes or No) | ሪፎርገት | Set 1 | Program set point 1 |
| ፎርገት | Units | Select the display units/tags | ሪፎርገት | Reset 1 | Program reset point 1 |
| ፎርገት | Decimal point | Set decimal point | ሪፎርገት | Relay 2 | Relays 2-8 setup <i>Note: Relays 5-8 are shown, only if expansion relay module is installed.</i> |
| ሪፎርገት | PV1 | PV1 decimal point (Level) | ፎርገት | Fail-safe | Enter Fail-safe menu |
| ሪፎርገት | PV2 | PV2 decimal point (Level) | ፎርገት | Fail-safe 1 | Set relay 1 fail-safe operation |
| ፎርገት | Program | Enter the Program menu | ፎርገት | On | Enable fail-safe operation |
| ፎርገት | Scale | Enter the Scale menu | ፎርገት | Off | Disable fail-safe operation |
| ፎርገት | Scale 1 | Enter the Scale menu for PV1 | ፎርገት | Fail-safe 2 | Set relays 2-8 fail-safe operation |
| ፎርገት | Scale 2 | Enter the Scale menu for PV2 | ፎርገት | Delay | Enter relay Time Delay menu |
| ፎርገት | Calibrate | Enter the Calibration menu | ፎርገት | Delay 1 | Enter relay 1 time delay setup |
| ፎርገት | Input 1 | Calibrate input 1 signal or program input 1 value | ፎርገት | On 1 | Set relay 1 On time delay |
| ፎርገት | Display 1 | Program display 1 value | ፎርገት | Off 1 | Set relay 1 Off time delay |
| ፎርገት | Input 2 | Calibrate input 2 signal or program input 2 value (up to 32 points) | ፎርገት | Delay 2 | Enter relays 2-8 time delay setup |
| ፎርገት | Display 2 | Program display 2 value (up to 32 points) | ፎርገት | Loop break | Set relay condition if loop break detected |
| ፎርገት | Error | Error, calibration not successful, check signal or programmed value | ፎርገት | Ignore | Ignore loop break condition (Processed as a low signal condition) |
| ፎርገት | Display | Enter the Display menu | ፎርገት | On | Relay goes to alarm condition when loop break is detected |
| ፎርገት | Display Line 1 | Press Enter to assign the Main display parameter (default: PV) | ፎርገት | Off | Relay goes to non-alarm condition when loop break is detected |
| ፎርገት | Display Line 2 | Press Enter to assign the small display parameter (default: engineering units) | ፎርገት | Analog output | Enter the Analog output scaling menu |
| ፎርገት | Display intensity | Set display intensity level from 1 to 8 | ፎርገት | Display 1 | Program display 1 value |
| ፎርገት | Relay | Enter the Relay menu | ፎርገት | Output 1 | Program output 1 value (e.g. 4.000 mA) |
| ፎርገት | Relay 1 | Relay 1 setup | ፎርገት | Display 2 | Program display 2 value |
| ፎርገት | Action 1 | Set relay 1 action | ፎርገት | Output 2 | Program output 2 value (e.g. 20.000 mA) |
| ፎርገት | Automatic | Set relay for automatic reset | ፎርገት | Reset | Press Enter to access the Reset menu |
| ፎርገት | Auto-manual | Set relay for automatic & manual reset any time | | | |
| ፎርገት | Latching | Set relay for latching operation | | | |

| Display | Parameter | Action/Setting Description |
|---------|------------------|---|
| rSt Hi | Reset high | Press Enter to reset max display |
| rSt Lo | Reset low | Press Enter to reset min display |
| rSt HL | Reset high & low | Press Enter to reset max & min displays |
| rSt tr | Reset tare | Reset tare |
| Control | Control | Enter Control menu |
| Auto | Automatic | Press Enter to set meter for automatic operation |
| man | Manual | Press Enter to manually control relays or analog output operation |

| Display | Parameter | Action/Setting Description |
|------------------|------------|--------------------------------|
| PASS | Password | Enter the Password menu |
| PASS 1 | Password 1 | Set or enter Password 1 |
| PASS 2 | Password 2 | Set or enter Password 2 |
| PASS 3 | Password 3 | Set or enter Password 3 |
| unLoc | Unlocked | Program password to lock meter |
| Locd | Locked | Enter password to unlock meter |
| 999999 -99999 | Flashing | Over/under range condition |

Main Menu

The main menu consists of the most commonly used functions: *Setup*, *Reset*, *Control*, and *Password*.

- Press Menu button to enter Programming Mode then press the Up arrow button to scroll main menu.
- Press Menu, at any time, to exit and return to Run Mode. Changes made to settings prior to pressing Enter are not saved.
- Changes to the settings are saved to memory only after pressing Enter/F3.
- The display moves to the next menu every time a setting is accepted by pressing Enter/F3.

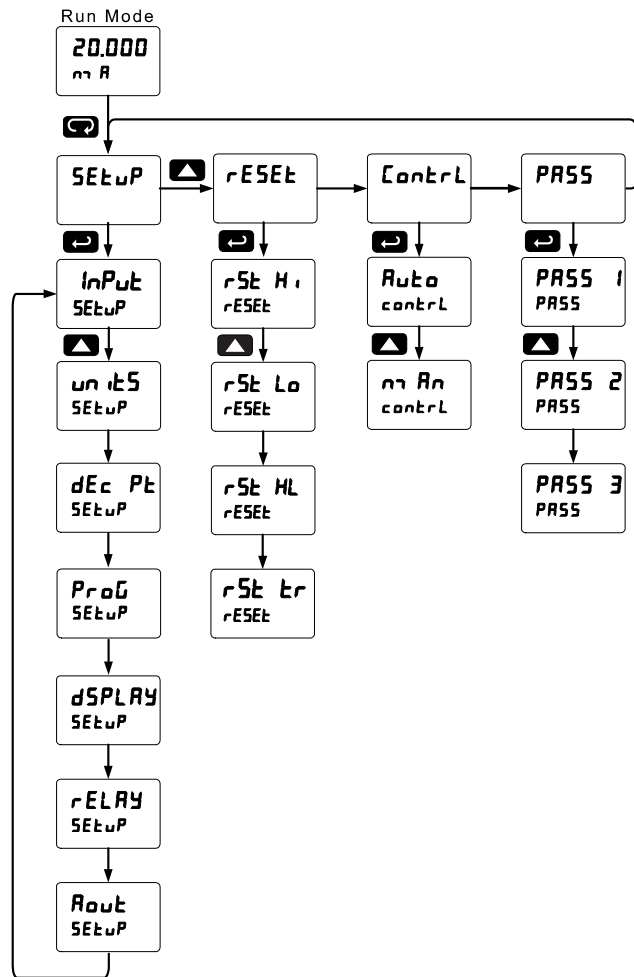

Setting Numeric Values

The numeric values are set using the Right and Up arrow buttons. Press Right arrow to select next digit and Up arrow to increment digit value.

The digit being changed is displayed brighter than the rest.

Press and hold up arrow to auto-increment the display value.

Press the Enter button, at any time, to accept a setting or Menu button to exit without saving changes.

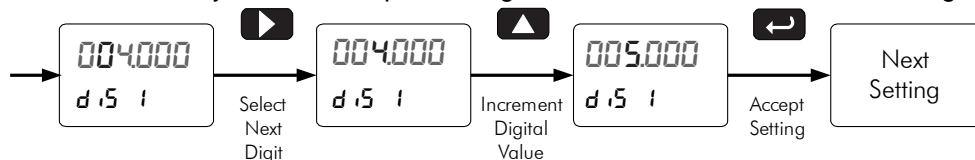

Setting Up the Meter (SEtUP)

The *Setup* menu is used to select:

1. Input signal the meter will accept
2. Dual-scale feature for some level applications
3. Select the display units/tags
4. Decimal point position
5. Programming Menu
6. Display parameter and intensity
7. Relay operation
8. 4-20 mA analog output scaling

Press the Enter button to access any menu or press Up arrow button to scroll through choices. Press the Menu button to exit at any time.

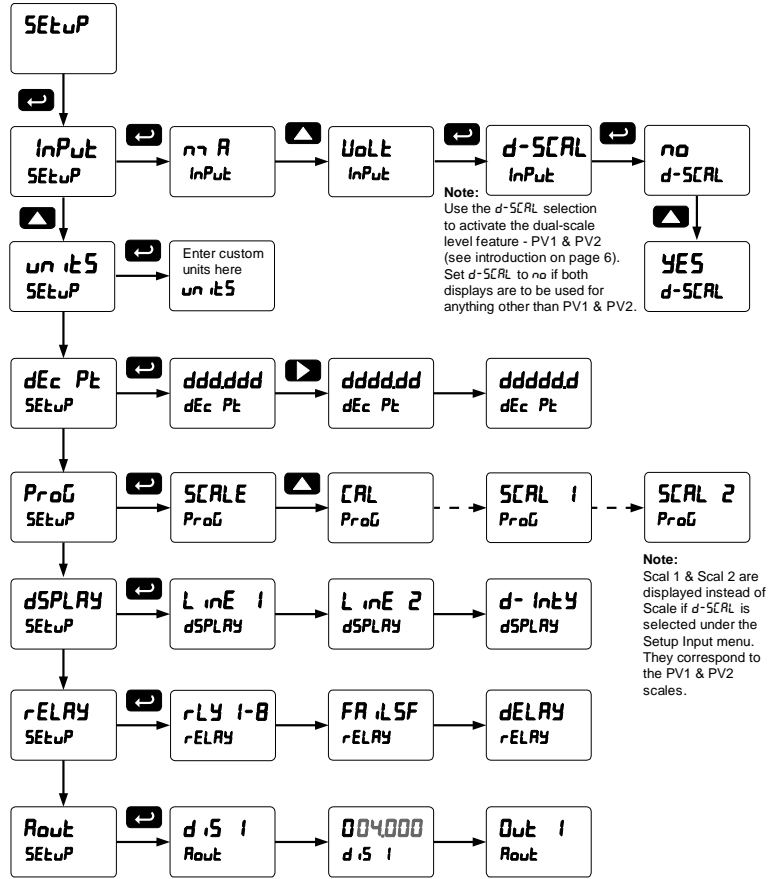

Setting the Input Signal (InPUt)

Enter the *Input* menu to set up the meter to display current (*mA*) or voltage (*Volt*) inputs.

The current input is capable of accepting any signal from 0 to 20 mA. Select current input to accept 0-20 mA or 4-20 mA signals.

The voltage input is capable of accepting any signal from -10 to +10 VDC. Select voltage input to accept 0-5, 1-5, 0-10, or ±10 VDC signals.

After selecting *mA* or *Volt* input, *d-SCAL* is displayed; press Enter to select “Yes” or “No”. Selecting “Yes” enables the dual-scale feature, which allows for the *Scale* (*SCALE*) and *Units* (*UNITS*) menus to be used to scale the same input in two different scales for PV1 & PV2.

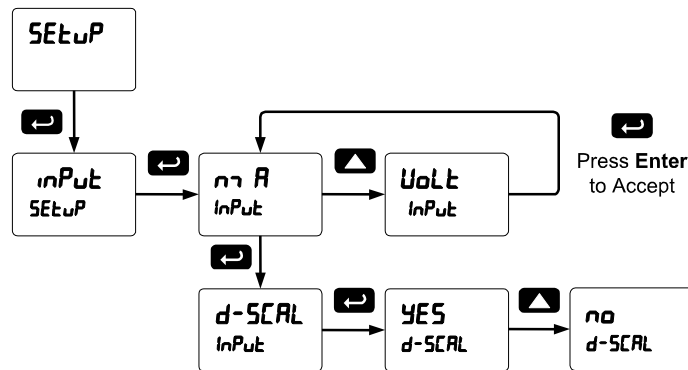

Set **d-SCAL** to no if both displays are to be used for anything other than PV1 & PV2.

Setting the Input Units or Custom Tags (dUnit)

Enter the input unit or custom tag that will be displayed if dUnit is selected as the line 2 parameter. See the flow chart on page 25 to access the display menu to show the unit or tag on display line 2. The engineering units or custom legends can be set using the following 7-segment character set:

| Display | Character | Display | Character | Display | Character | Display | Character |
|---------|-----------|---------|-----------|---------|-----------|---------|-----------|
| 0 | 0 | C | C | K | K | v | V |
| 1 | 1 | c | c | L | L | w | w |
| 2 | 2 | d | d | m | m | X | X |
| 3 | 3 | E | E | n | n | Y | Y |
| 4 | 4 | F | F | O | O | Z | Z |
| 5 | 5 | G | G | o | o | - | - |
| 6 | 6 | g | g | P | P | / | / |
| 7 | 7 | H | H | q | q |] |] |
| 8 | 8 | h | h | r | r | [| [|
| 9 | 9 | I | I | S | S | = | = |
| A | A | i | i | t | t | ° | Degree(<) |
| b | b | J | J | u | u | | Space |

Notes:

Degree symbol represented by (<) if programming with MeterView® Pro.

The letters “m” and “w” use two 7-segment LEDs each; when selected the characters to the right are shifted one position.

Press and hold up arrow to auto-scroll the characters in the display.

Setting the Decimal Point (dPt)

The decimal point may be set with up to five decimal places or with no decimal point at all.

Pressing the Right arrow moves the decimal point one place to the right until no decimal point is displayed, and then it moves to the leftmost position. Pressing the Up arrow moves the decimal point one place to the left.

If the dual-scale level feature is selected, the decimal point selections for PV1 & PV2 are enabled.

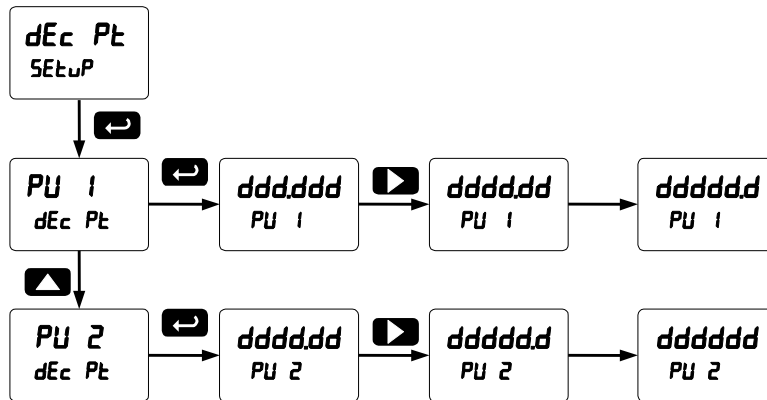

Programming the Meter (Prog)

It is **very important** to read the following information, before proceeding to program the meter:

- The meter is factory calibrated prior to shipment to read in milliamps and volts depending on the input selection. The calibration equipment is certified to NIST standards.
- Use the *Scale* menu to scale the process input (e.g. 4-20 mA). A calibrated signal source is not needed to scale the meter.
- Use the *Calibrate* menu to apply a signal from a calibrator or a flowmeter.
- The PD6000 is a single input meter with dual-scale capability.

The *Program* menu contains the *Scale* and the *Calibrate* menus.

*Note: The **Scale** and **Calibrate** functions are exclusive of each other. The meter uses the last function programmed. Only one of these methods can be employed at a time. The Scale and Calibrate functions can use up to 32 points (default is 2). The number of points should be set in the Advanced menu under the Multi-Point Linearization (**LINEAR**) menu selection prior to scaling and calibration of the meter, see page 41 for details.*

If the dual-scale level feature is selected in the *Setup* menu, the *Scale 1* and *Scale 2* menus are enabled for PV1 & PV2 respectively.

The process input may be calibrated or scaled to any display value within the range of the meter.

Program Menu for Single Scale Process

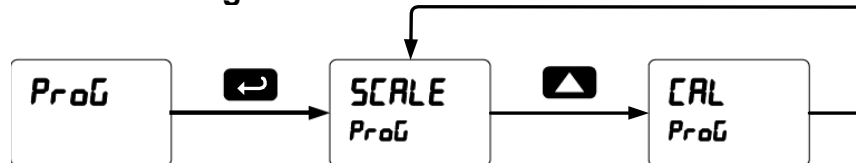

Program Menu for Dual-Scale Level Applications

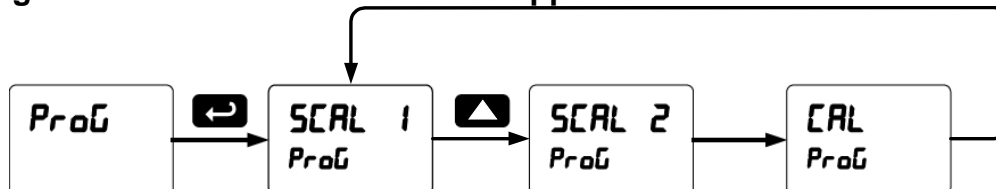

Additional parameters, not needed for most applications, are programmed in the *Advanced Features* menu; see *Advanced Features Menu*, page 38.

Multi-Point Calibration & Scaling

The meter is set up at the factory for 2-point linear calibration. The number of points for multi-point calibration/scaling is set up in the *Advanced Features* menu. Up to 32 linearization points may be selected for PV1 and up to 8 linearization points may be selected for PV2. See page 41 for details.

Scaling the Meter (SCALE)

The process input (4-20 mA, ±10 VDC) can be scaled to display the process variable in engineering units. A signal source is not needed to scale the meter; simply program the inputs and corresponding display values.

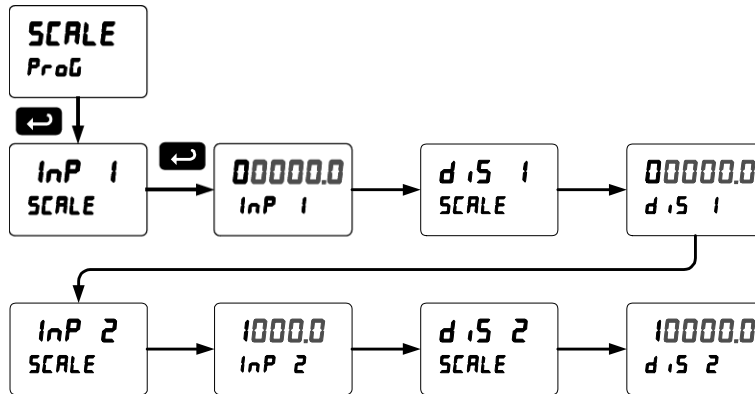

For instructions on how to program numeric values see *Setting Numeric Values*, page 19.

Dual-Scale for Level Application

The analog input can be displayed in two different scales, by enabling the dual-scale feature (**d-SCALE**) in the *Setup-Input* menu, see page 20.

To enable the dual-scale feature for some level applications you must select d-SCAL in the Input selection menu.

Scaling the Input for PV1 (SCAL 1)

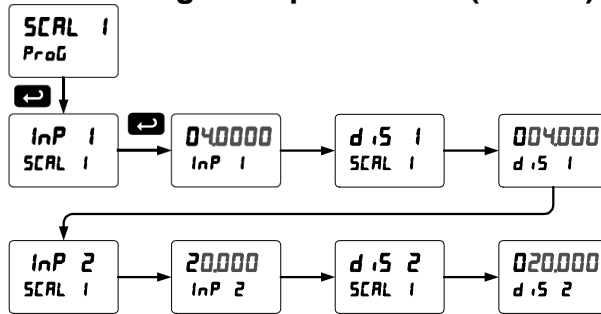

Scaling the Input for PV2 (SCAL 2)

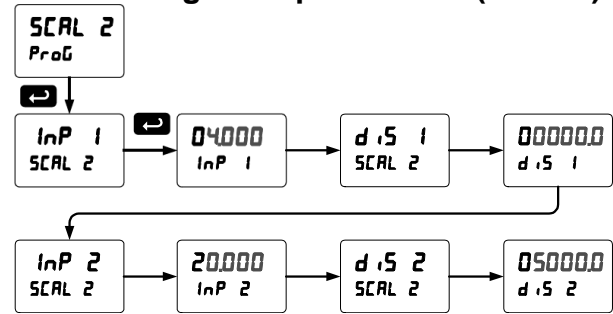

Error Message (Error)

An error message indicates that the calibration or scaling process was not successful.

After the error message is displayed, the meter reverts to the input prior to the failure during calibration or scaling and to input 1 during internal calibration, allowing the appropriate input signal to be applied or programmed.

The error message might be caused by any of the following conditions:

1. Input signal is not connected to the proper terminals or it is connected backwards.
2. Wrong signal selection in *Setup* menu.
3. Minimum input span requirements not maintained.
4. Input 1 signal inadvertently applied to calibrate input 2.

Minimum Input Span

The minimum input span is the minimum difference between input 1 and input 2 signals required to complete the calibration or scaling of the meter.

| Input Range | Input 1 & Input 2 Span |
|-------------|------------------------|
| 4-20 mA | 0.15 mA |
| ±10 VDC | 0.01 VDC |

Calibrating the Meter with External Source (Cal)

Note: To scale the meter without a signal source refer to Scaling the Meter (SCALE), page 23.

The meter can be calibrated to display the process variable in engineering units by applying the appropriate input signal and following the calibration procedure. The use of a calibrated signal source is strongly recommended to calibrate the meter.

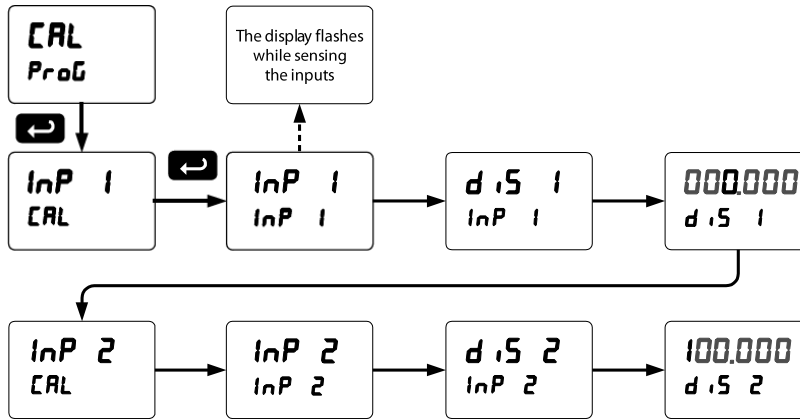

Warm up the meter for at least 15 minutes before performing calibration to ensure specified accuracy.

Setting the Display Parameter & Intensity (dSPRAY)

The main display (LINE 1) can be programmed to display:

1. Process value 1 (PV1)
2. Process value 2 (PV2)
3. Percent of PV1 (PCT)
4. Relay set points
5. Max & min values
6. Modbus input
7. Display reading and units
8. Display gross
9. Toggle net & gross

The secondary display (LINE 2) can be programmed to display:

1. Unit
2. Process value 1 (PV1)
3. Process value 2 (PV2)
4. Percent of PV1 (PCT)
5. Relay set points
6. Max & min values
7. Engineering units or custom legends
8. Modbus input
9. Off (no display)
10. Toggle reading and units
11. Display gross
12. Toggle net/gross

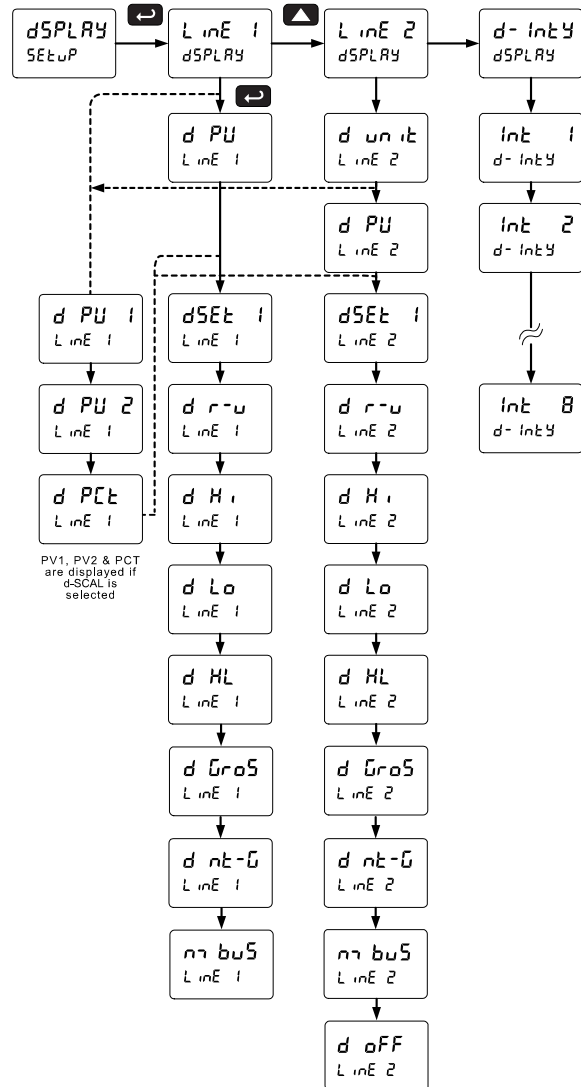

Display Intensity: The meter has eight display intensity levels to give the best performance under various lighting conditions. Select intensity 8 for outdoor applications. The default intensity setting is 8.

After setting up the input and display, press the Menu button to exit programming and skip the rest of the setup menu. Press the Menu button again and the Up arrow to reach the *Program* menu and complete the scaling or calibration of the meter.

Setting the Relay Operation (rELAY)

This menu is used to set up the operation of the relays.



Caution! During setup, the relays do not follow the input and they will remain in the state found prior to entering the Relay menu.

1. Relay action
 - a. Automatic reset only (non-latching)
 - b. Automatic + manual reset at any time (non-latching)
 - c. Latching (manual reset only)
 - d. Latching with Clear (manual reset only after alarm condition has cleared)
 - e. Pump alternation control (automatic reset only)
 - f. Sampling (the relay is activated for a user-specified time)
 - g. Off (relay state controlled by Interlock feature)
2. Set point
3. Reset point
4. Fail-safe operation
 - a. On (enabled)
 - b. Off (disabled)
5. Time delay
 - a. On delay (0-999.9 seconds)
 - b. Off delay (0-999.9 seconds)
6. Relay action for loss (break) of 4-20 mA input (ignore, on, off)

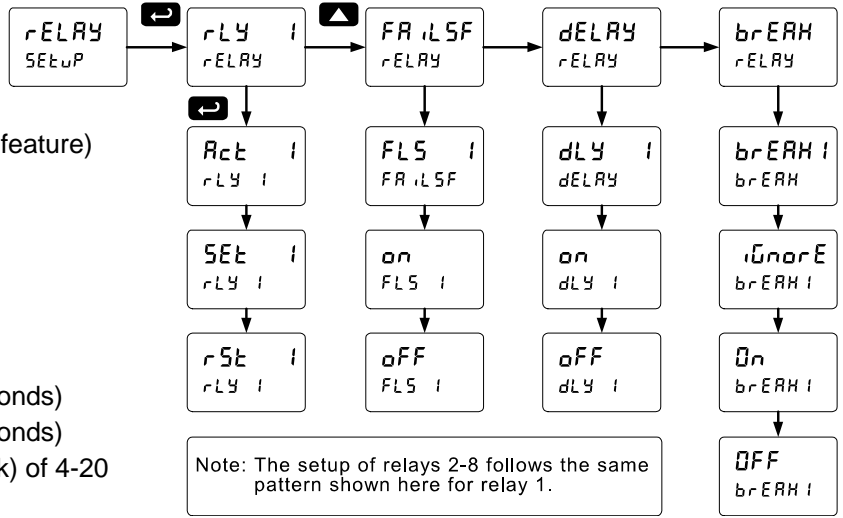

Setting the Relay Action

Operation of the relays is programmed in the *Action* menu. The relays may be set up for any of the following modes of operation:

1. Automatic reset (non-latching)
2. Automatic + manual reset at any time (non-latching)
3. Latching (manual reset only, at any time)
4. Latching with Clear (manual reset only after alarm condition has cleared)
5. Pump alternation control (automatic reset only)
6. Sampling (the relay is activated for a user-specified time)
7. Off (relay state controlled by Interlock feature)

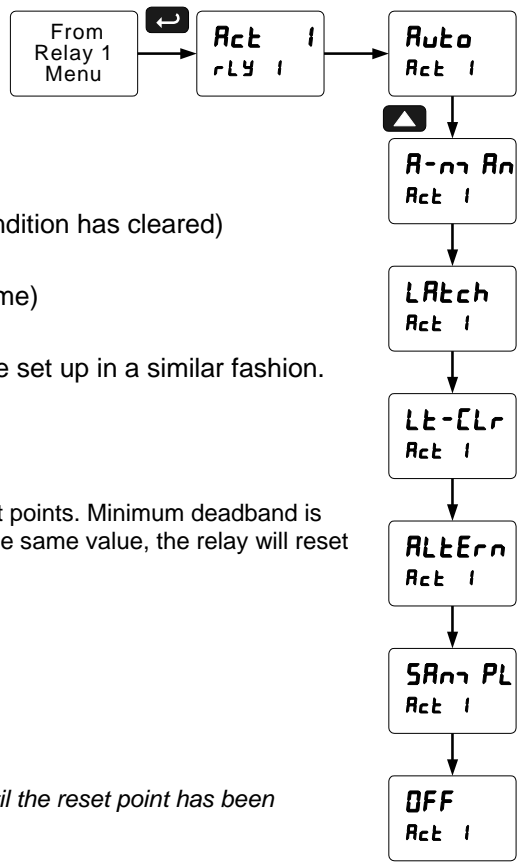

The following graphic shows relay 1 action setup; relay 2-8 are set up in a similar fashion.

Programming Set and Reset Points

High alarm indication: program set point above reset point.

Low alarm indication: program set point below reset point.

The deadband is determined by the difference between set and reset points. Minimum deadband is one display count. If the set and reset points are programmed with the same value, the relay will reset one count below the set point.

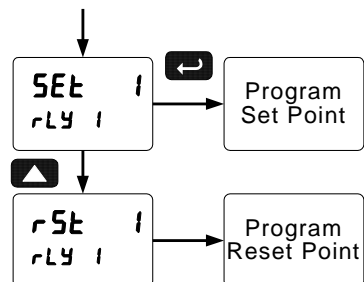

Note: Changes are not saved until the reset point has been accepted.

Setting Fail-Safe Operation

In fail-safe mode of operation, the relay coil is energized when the process variable is within safe limits and the relay coil is de-energized when the alarm condition exists. The fail-safe operation is set independently for each relay. Select **on** to enable or select **off** to disable fail-safe operation.

Programming Time Delay

The *On* and *Off* time delays may be programmed for each relay between 0 and 999.9 seconds. The relays will transfer only after the condition has been maintained for the corresponding time delay.

The *On* time delay is associated with the set point.

The *Off* time delay is associated with the reset point.

Relay Action for Loss of 4-20 mA Input (Loop Break)

The loop break feature is associated with the 4-20 mA input. Each relay may be programmed to go to one of the following conditions when the meter detects the loss of the input signal (i.e. < 0.005 mA):

1. Turn *On* (Go to alarm condition)
2. Turn *Off* (Go to non-alarm condition)
3. Ignore (Processed as a low signal condition)

Note: This is not a true loop break condition; if the signal drops below 0.005 mA, it is interpreted as a "loop break" condition.

Relay and Alarm Operation Diagrams

The following graphs illustrate the operation of the relays, status LEDs, and ACK button.

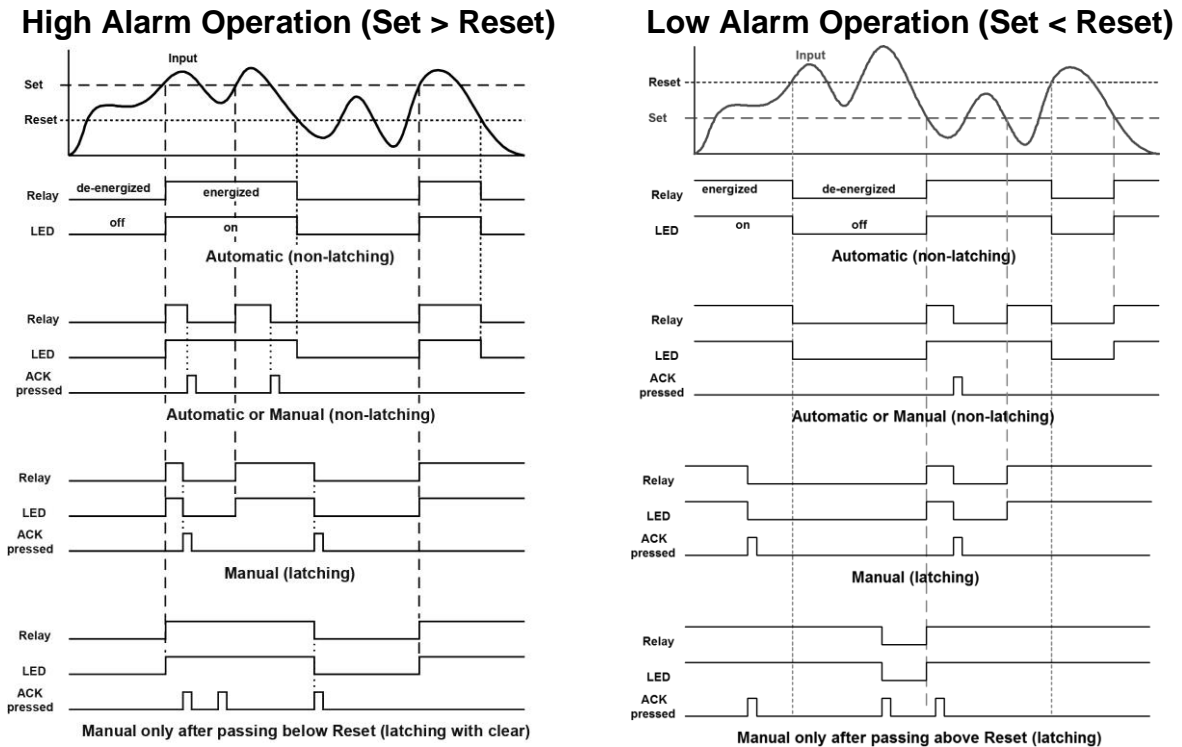

For Manual reset mode, ACK can be pressed anytime to turn "off" relay. To detect a new alarm condition, the signal must go below the set point, and then go above it.

For Manual reset mode, ACK can be pressed anytime to turn "off" relay. For relay to turn back "on", signal must go above set point and then go below it.

High Alarm with Fail-Safe Operation (Set > Reset)

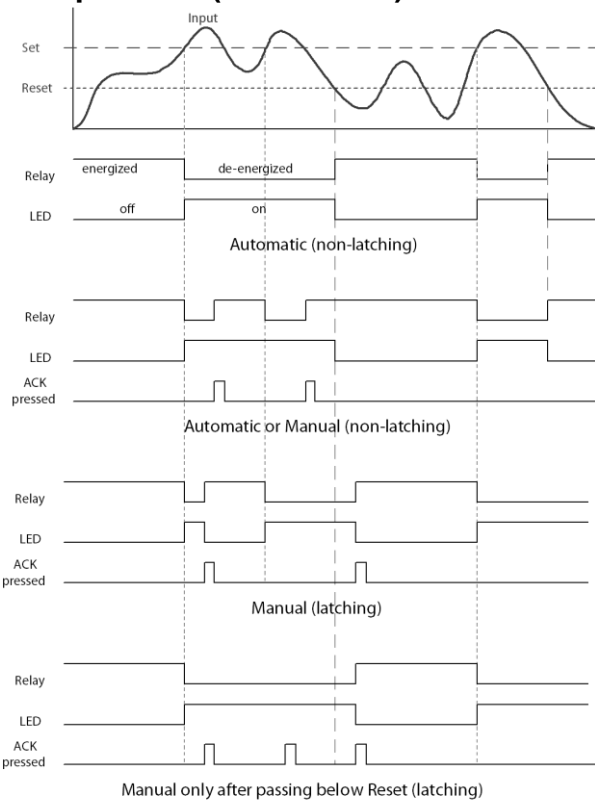

Note: Relay coil is energized in non-alarm condition. In case of power failure, relay will go to alarm state.

Low Alarm with Fail-Safe Operation (Set < Reset)

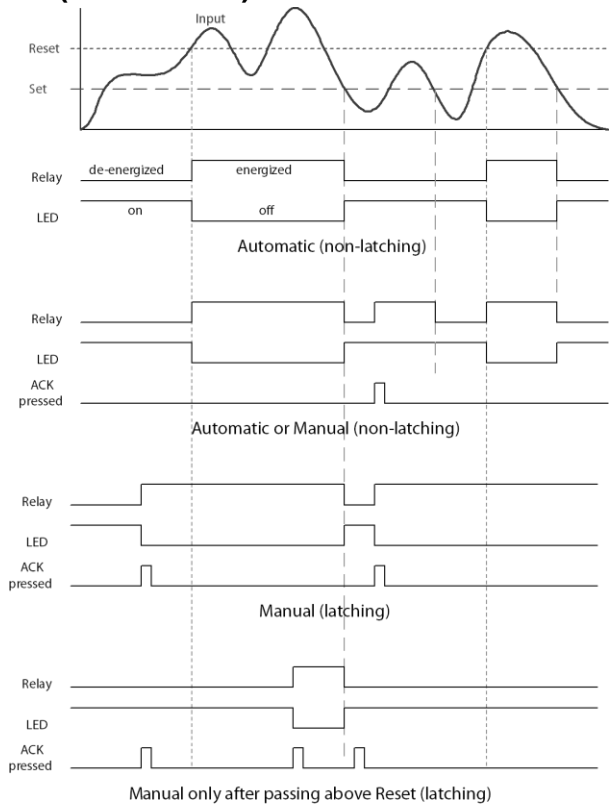

Note: Relay coil is energized in non-alarm condition. In case of power failure, relay will go to alarm state.

Pump Alternation Control Operation

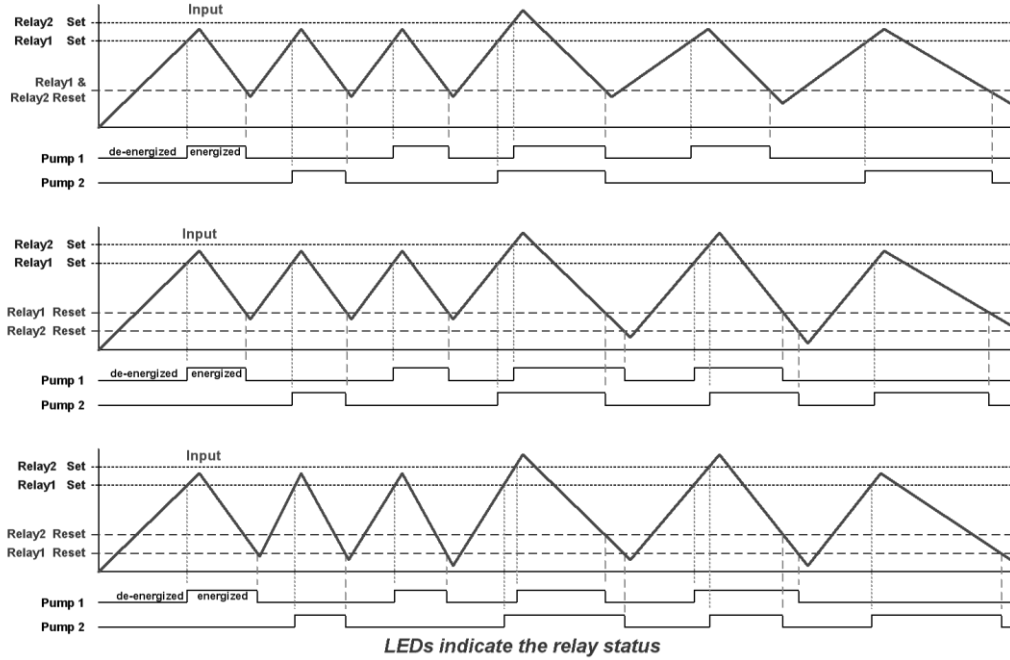

Relay Sampling Operation

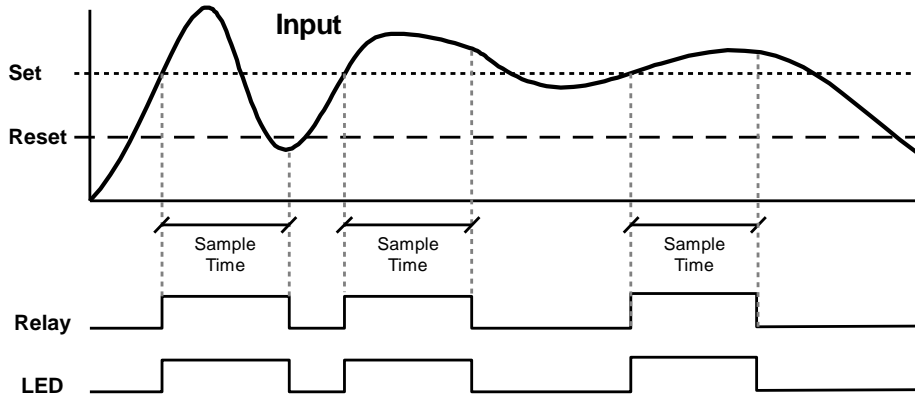

When the signal crosses the set point, the relay trips and the sample time starts. After the sample time has elapsed, the relay resets. The cycle repeats every time the set point is crossed, going up for high alarms and going down for low alarms.

The sample time can be programmed between 0.1 and 5999.9 seconds.

Signal Loss or Loop Break Relay Operation

The following graph shows the loop break relay operation for a high alarm relay.

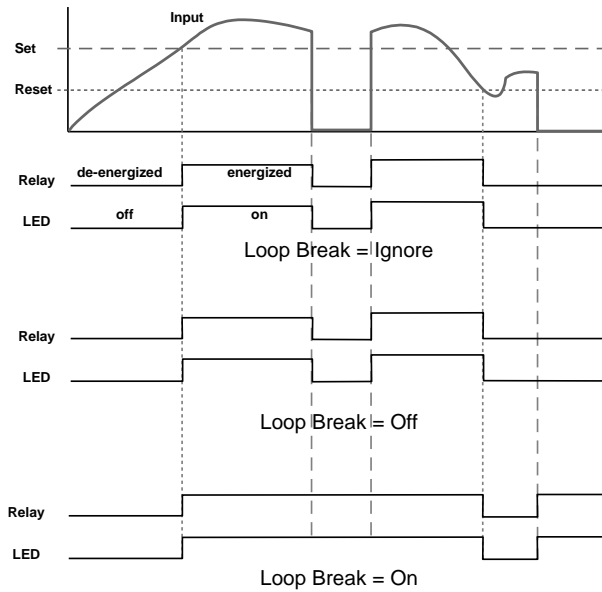

When the meter detects a break in the 4-20 mA loop, the relay will go to one of the following selected actions:

1. Turn *On* (Go to alarm condition)
2. Turn *Off* (Go to non-alarm condition)
3. Ignore (Processed as a low signal condition)

Time Delay Operation

The following graphs show the operation of the time delay function.

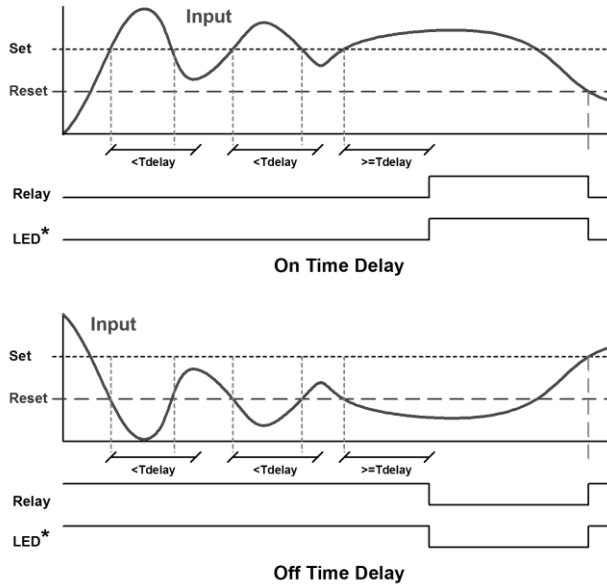

When the signal crosses the set point, the *On* time delay timer starts and the relay trips when the time delay has elapsed. If the signal drops below the set point (high alarm) before the time delay has elapsed, the *On* time delay timer resets and the relay does not change state. The same principle applies to the *Off* time delay.

Note: If "Automatic or Manual (R-n Rn)" reset mode is selected, the LED follows the reset point and not the relay state when the relay is acknowledged.

Relay Operation Details

Overview

The relay capabilities of the meter expand its usefulness beyond simple indication to provide users with alarm and control functions. These capabilities include front panel alarm status LEDs as well as either 2 or 4 optional internal relays and/or 4 external relays expansion module. Typical applications include high or low temperature, level, pressure or flow alarms, control applications such as simple on/off pump control, and pump alternation control for up to 8 pumps. There are four basic ways the relays can be used:

1. High or Low Alarms with Latching or Non-Latching Relays
2. Simple On/Off Control with 100% Adjustable Deadband
3. Sampling (Based on Time)
4. Pump Alternation Control for up to 8 Pumps

Relays Auto Initialization

When power is applied to the meter, the front panel LEDs and alarm relays will reflect the state of the input to the meter. The following table indicates how the alarm LEDs and relays will react on power-up based on the set and reset points:

| Alarm # | HI or LO Alarm | Set Point | Reset Point | Power-Up Reading | Relay & LED |
|---------|----------------|-----------|-------------|------------------|-------------|
| 1 | HI | 1000 | 500 | 499 | Off |
| 2 | LO | 700 | 900 | 499 | On |
| 3 | LO | 250 | 400 | 499 | Off |
| 4 | HI | 450 | 200 | 499 | On |

Fail-Safe Operation

The following table indicates how the relays behave based on the fail-safe selection for each relay:

Note: NO = Normally Open, NC = Normally Closed. This refers to the condition of the relay contacts when the power to the meter is off.

| Fail-Safe Selection | Non-Alarm State | | Alarm State | | Power Failure |
|---------------------|-----------------|--------|-------------|--------|------------------------------|
| | NO | NC | NO | NC | |
| Off | Open | Closed | Closed | Open | Relays go to non-alarm state |
| On | Closed | Open | Open | Closed | Relays go to alarm state |

Front Panel LEDs

The LEDs on the front panel provide status indication for the following:

The meter is supplied with four alarm points that include front panel LEDs to indicate alarm conditions. This standard feature is particularly useful for alarm applications that require visual-only indication. The LEDs are controlled by the set and reset points programmed by the user. When the display reaches a set point for a high or low alarm, the corresponding alarm LED will turn on. When the display returns to the reset point the LED will go off. The front panel LEDs respond differently for latching and non-latching relays.

| LED | Status |
|-----|---------|
| 1 | Alarm 1 |
| 2 | Alarm 2 |
| 3 | Alarm 3 |
| 4 | Alarm 4 |

| LED | Status |
|-----|---------|
| 5 | Alarm 5 |
| 6 | Alarm 6 |
| 7 | Alarm 7 |
| 8 | Alarm 8 |

When the display reaches a set point for a high or low alarm, the corresponding alarm LED will turn on. When the display returns to the reset point the LED will go off. The front panel LEDs respond differently for latching and non-latching relays.

For non-latching relays, the LED is always off during normal condition and always on during alarm condition, regardless of the state of the relay (e.g. Relay acknowledged after alarm condition).

For latching relays, the alarm LEDs reflect the status of the relays, regardless of the alarm condition. The following tables illustrate how the alarm LEDs function in relation to the relays and the acknowledge button (Default: F3 key assigned to ACK).

Latching and Non-Latching Relay Operation

The relays can be set up for latching (manual reset) or non-latching (automatic reset) operation.

The On and Off terminology does not refer to the status of the relay's coil, which depends on the fail-safe mode selected.

Relay terminology for following tables

| Terminology | Relay Condition |
|-------------|-----------------|
| On | Alarm (Tripped) |
| Off | Normal (Reset) |
| Ack | Acknowledged |



Warning! *In latching relay mode, latched relays will reset (unlatch) when power is cycled.*

Non-Latching Relay (R_ut_o)

In this application, the meter is set up for automatic reset (non-latching relay). Acknowledging the alarm while it is still present has no effect on either the LED or the relay. When the alarm finally goes away, the relay automatically resets and the LED also goes off.

| Automatic reset only | | |
|----------------------|-----|-------|
| Condition | LED | Relay |
| Normal | Off | Off |
| Alarm | On | On |
| Ack (No effect) | On | On |
| Normal | Off | Off |

Non-Latching Relay (R_u-*n* R_n)

In this application, the meter is set up for automatic and manual reset at any time (non-latching relay). The LED and the relay automatically reset when the meter returns to the normal condition.

The next time an alarm occurs, the operator acknowledges the alarm manually while the alarm condition still exists. This causes the relay to reset, but the LED stays on until the meter returns to the normal condition.

| Automatic + manual reset at any time | | |
|--------------------------------------|-----|-------|
| Condition | LED | Relay |
| Normal | Off | Off |
| Alarm | On | On |
| Normal | Off | Off |
| Next Alarm | On | On |
| Ack | On | Off |
| Normal | Off | Off |

Latching Relay (L_Rl_cH)

In this application, the meter is set up for manual reset at any time. Acknowledging the alarm even if the alarm condition is still present resets the relay and turns off the LED.

| Manual reset any time | | |
|-----------------------|-----|-------|
| Condition | LED | Relay |
| Normal | Off | Off |
| Alarm | On | On |
| Ack | Off | Off |

Latching Relay (L_L-[L_r)

In this application, the meter is set up for manual reset only after the signal passes the reset point (alarm condition has cleared). Acknowledging the alarm while it is still present has no effect on either the LED or the relay. When the alarm is acknowledged after it returns to the normal state, the LED and the relay go off. Notice that the LED remains on, even after the meter returns to the normal condition. This is because, for latching relays, the alarm LED reflects the status of the relay, regardless of the alarm condition.

| Manual reset only after alarm condition has cleared | | |
|---|-----|-------|
| Condition | LED | Relay |
| Normal | Off | Off |
| Alarm | On | On |
| Ack (No effect) | On | On |
| Normal | On | On |
| Ack | Off | Off |

Acknowledging Relays

There are two ways to acknowledge relays programmed for manual reset:

1. Via the programmable front panel function keys F1-F3 (Default: F3 assigned to ACK).
2. Remotely via a normally open pushbutton wired across one of the digital inputs and the +5 V terminals on the digital I/O modules, or using the F4 digital input, which is triggered with a contact closure to COM, or with an active low signal (see page 14).

When the ACK button or the assigned digital input is closed, all relays programmed for manual reset are acknowledged.

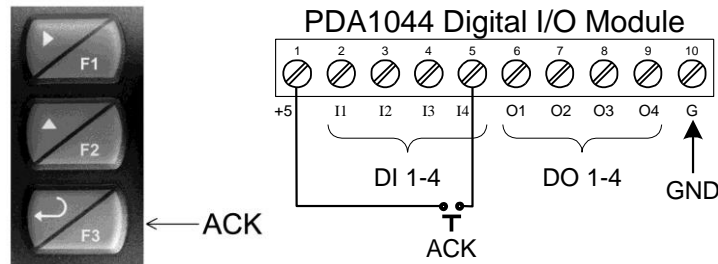

Figure 20. Acknowledge Relays w/Function Key or Digital Input

Pump Alternation Control Applications (RLLErn)

For pump control applications where two or more similar pumps are used to control the level of a tank or a well, it is desirable to have all the pumps operate alternately. This prevents excessive wear and overheating of one pump over the lack of use of the other pumps.

Up to 8 relays can be set up to alternate every time an on/off pump cycle is completed. The set points and reset points can be programmed, so that the first pump on is the first pump off.

Application #1: Pump Alternation Using Relays 1 & 2

1. Relays 1 and 2 are set up for pump alternation.
2. Relays 3 and 4 are set up for low and high alarm indication.

| Set and Reset Point Programming | | | |
|---------------------------------|-----------|-------------|---------------------|
| Relay | Set Point | Reset Point | Function |
| 1 | 30.000 | 10.000 | Controls pump #1 |
| 2 | 35.000 | 5.000 | Controls pump #2 |
| 3 | 4.000 | 9.000 | Controls low alarm |
| 4 | 40.000 | 29.000 | Controls high alarm |

Pump Alternation Operation

1. Pump #1 turns on when level reaches 30.000, when level drops below 10.000, pump #1 turns off.
2. The next time level reaches 30.000, pump #2 turns on, when level drops below 10.000, pump #2 turns off.
3. If the level doesn't reach 35.000, pump #1 and pump #2 will be operating alternately.
4. If pump #1 cannot keep the level below 35.000, pump #2 will turn on at 35.000, then as the level drops to 10.000, pump #1 turns off, pump #2 is still running and shuts off below 5.000.
5. Notice that with the set and reset points of pump #2 outside the range of pump #1, the first pump on is the first pump to go off. This is true for up to 8 alternating pumps, if setup accordingly.
6. Relay #3 will go into alarm if the level drops below 4.000 and relay #4 will go into alarm if the level exceeds 40.000.
7. Adding the 4 external relays, expansion module allows using the 4 SPDT internal relays for pump alternation and the 4 SPST external relays for high, high-high, low, and low-low alarm indication.

Application #2: Pump Alternation Using Relays 3 & 4

1. Relays 1 and 2 are set up for low and high alarm indication.
2. Relays 3 and 4 are set up for pump alternation.

| Set and Reset Point Programming | | | |
|---------------------------------|-----------|-------------|----------------------|
| Relay | Set Point | Reset Point | Function |
| 1 | 495 | 750 | Controls low alarm |
| 2 | 7500 | 6900 | Controls high alarm |
| 3 | 7000 | 900 | Controls backup pump |
| 4 | 6000 | 1000 | Controls main pump |

The following graphics provide a visual representation of a typical pump alternation application with high and low alarm monitoring:

1. Relay #4 turns the main pump on at 6000 gallons and turns it off at 1000 gallons.

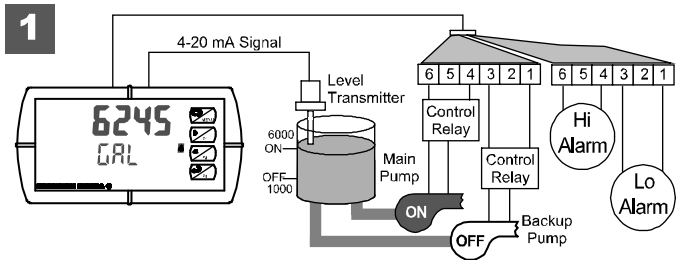

2. With the Pump Alternation feature activated, the next time the level reaches 6000 gallons, relay #3 transfers and starts the backup pump.

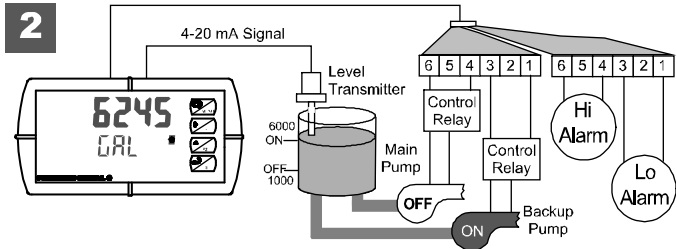

3. If the backup pump is not able to keep up, and the level reaches 7000 gallons, relay #4 transfers and starts the main pump as well.

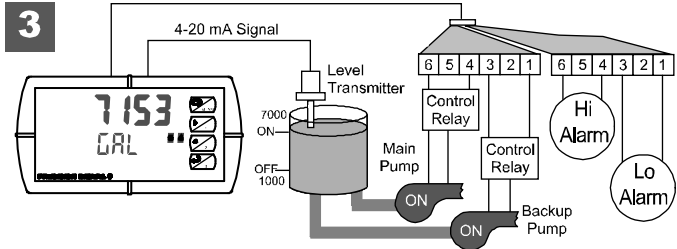

4. Relay #2 trips the High Level Alarm at 7500 gallons and resets at 6900 gallons.

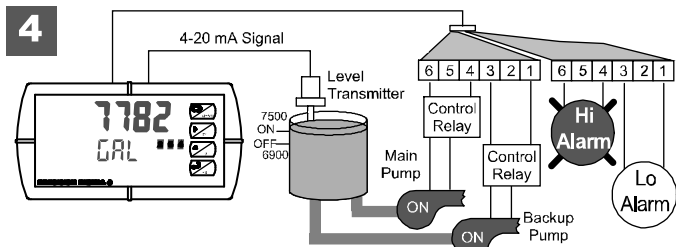

5. Relay #1 trips the Low Level Alarm at 495 gallons and resets at 750 gallons.

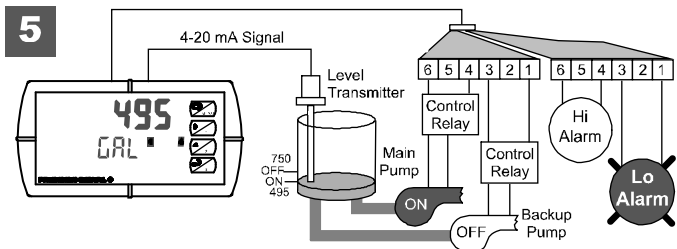

Setting Up the Interlock Relay (Force On) Feature

Relays 1-4 can be set up as interlock relays. To set up the relays for the interlock feature:

1. Access the *Setup – Relay – Action* menu and set the action to off.

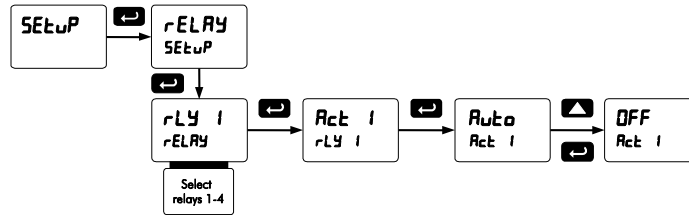

2. In the Advanced features – *User* menu program any of the digital inputs to *Force On* any of the internal relays (1-4).

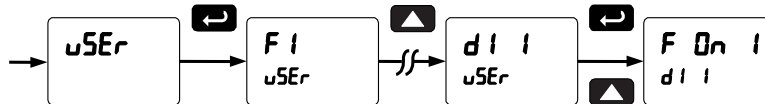

3. Connect a switch or dry contact between the +5V terminal and the corresponding digital input (dl-1 to dl-4) terminal.

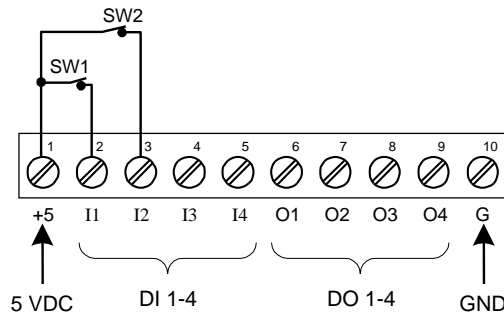

Interlock Relay Operation Example

Relays 1 & 2 are configured to energize (their front panel LEDs are off) when SW1 & SW2 switches (above) are closed. If the contacts to these digital inputs are opened, the corresponding front panel LEDs flash indicating this condition. The processes being controlled by the interlock relay will stop, and will re-start only after the interlock relay is re-activated by the digital inputs (switches).

Note: If multiple digital inputs are assigned to the same relay, then the corresponding logic is (AND) – i.e. both switches must be closed to trip the relay.

Scaling the 4-20 mA Analog Output (Rout)

The 4-20 mA analog output can be scaled to provide a 4-20 mA signal for any display range selected.

No equipment is needed to scale the analog output; simply program the display values to the corresponding mA output signal.

The *Analog Output* menu is used to program the 4-20 mA output based on display values.

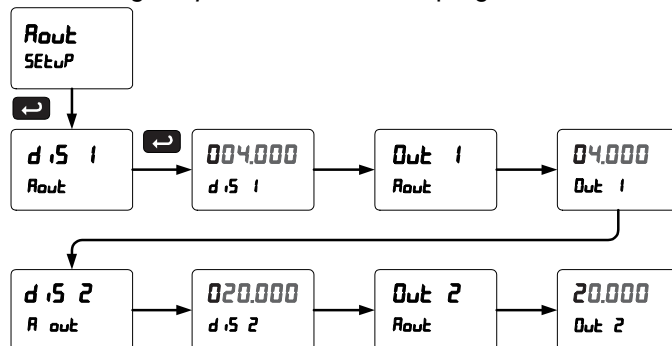

For instructions on how to program numeric values see *Setting Numeric Values*, page 19.

Reset Menu (rESEt)

The *Reset* menu is used to reset the maximum or minimum reading (peak or valley) reached by the process; both may be reset at the same time by selecting “reset high & low” (r5t HL). The tare value used to zero the display may be reset by selecting “reset tare” (r5t tR).

Control Menu (Contrl)

The *Control* menu is used to control the 4-20 mA analog output and the relays manually, ignoring the input. Each relay and analog output can be programmed independently for manual control. Selecting automatic control sets all relays and analog output for automatic operation.

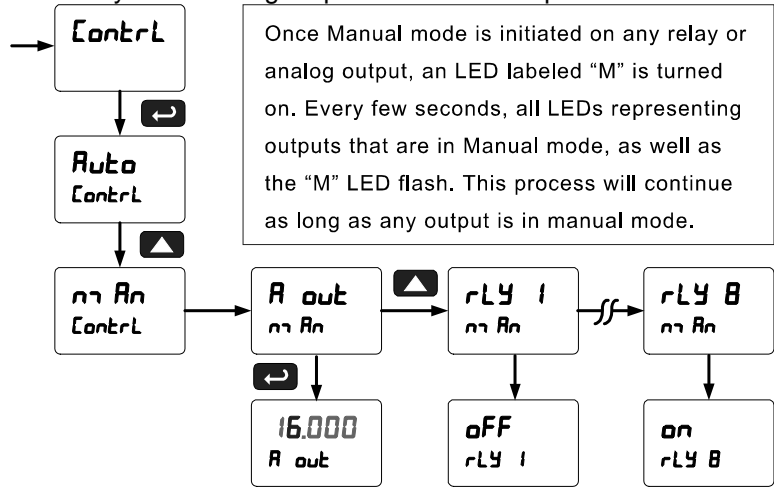

Setting Up the Password (PASS)

The *Password* menu is used for programming three levels of security to prevent unauthorized changes to the programmed parameter settings.

- Pass 1: Allows use of function keys and digital inputs
- Pass 2: Allows use of function keys, digital inputs and editing set/reset points
- Pass 3: Restricts all programming, function keys, and digital inputs.

Protecting or Locking the Meter

Enter the *Password* menu and program a six-digit password.

For instructions on how to program numeric values see *Setting Numeric Values*, page 19.

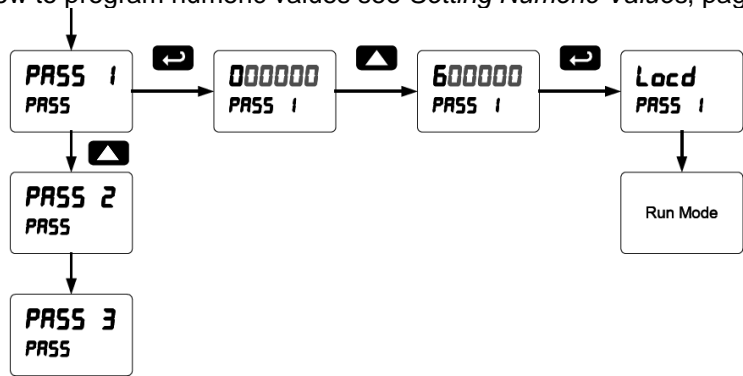

Making Changes to a Password Protected Meter

If the meter is password protected, the meter will display the message *L_oc_d* (*Locked*) when the Menu button is pressed. Press the Enter button while the message is being displayed and enter the correct password to gain access to the menu. After exiting the programming mode, the meter returns to its password protected condition.

Disabling Password Protection

To disable the password protection, access the *Password* menu and enter the correct password twice, as shown below. The meter is now unprotected until a new password is entered.

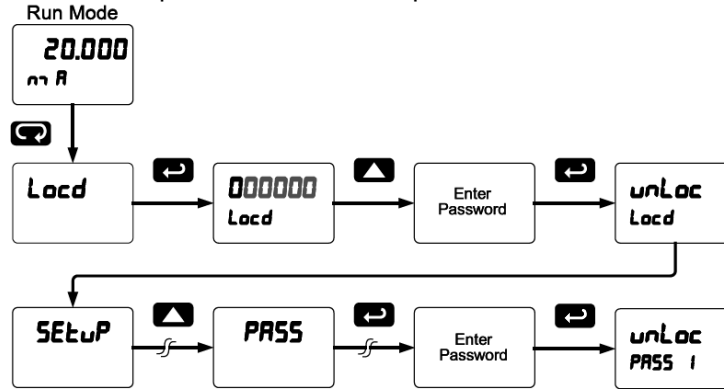

If the correct six-digit password is entered, the meter displays the message *u n L o c* (*unlocked*) and the protection is disabled until a new password is programmed.

If the password entered is incorrect, the meter displays the message *L o c d* (*Locked*) for about two seconds, and then it returns to Run Mode. To try again, press Enter while the *Locked* message is displayed.

Did you forget the password?

The password may be disabled by entering a master password once. If you are authorized to make changes, enter the master password 508655 to unlock the meter.

Advanced Features Menu

To simplify the setup process, functions not needed for most applications are located in the *Advanced Features* menu.

Press and hold the Menu button for three seconds to access the advanced features of the meter.

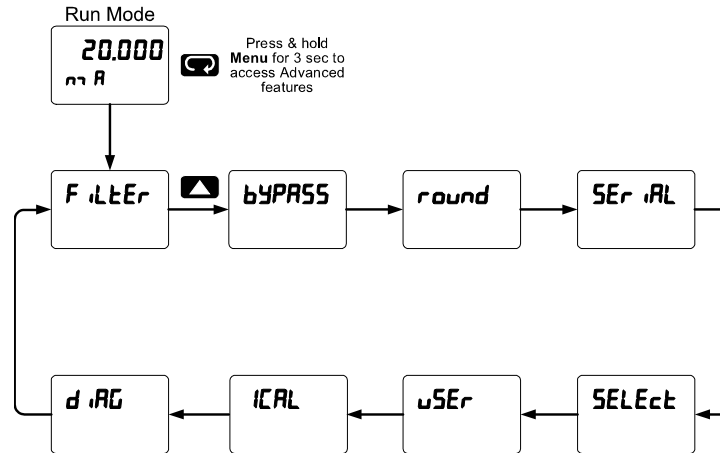

Advanced Features Menu & Display Messages

The following table shows the functions and messages of the *Advanced Features* menu in the order they appear in the menu.

| Display | Parameter | Action/Setting | Display | Parameter | Action/Setting |
|---------------------------|---------------------------|--|---------------------|---------------------------|--|
| F i L T E r | Filter | Set noise filter value | Pr o g E | Programmable exponent | Set meter for programmable exponent and enter exponent value |
| b Y P A S S | Bypass | Set filter bypass value | r h t | Round horizontal tank | Set meter for round horizontal tank volume calculation |
| r o u n d | Round | Set the rounding value for display variables | l n c h | Dimension | Calculate volume in gallons |
| S E R I A L | Serial | Set serial communication parameters | l r | Dimension | Calculate volume in liters |
| S l a v e I d | Slave ID | Set slave ID or meter address | d i a m | Diameter | Enter the tank's diameter in inches |
| b a u d | Baud rate | Select baud rate | l e n g t h | Length | Enter the tank's length in inches |
| t r a n s m i t d e l a y | Transmit delay | Set transmit delay for serial communication | C u t o f f | Cutoff | Set low-flow cutoff |
| P a r i t y | Parity | Select parity Even, Odd, or None with 1 or 2 stop bits | A n a l o g P r | Analog output programming | Program analog output parameters |
| t i m e b y t e | Time byte | Set byte-to-byte timeout | S o u r c e | Source | Select source for the 4-20 mA output |
| S E L E c t | Select | Enter the Select menu (function, cutoff, out) | O v e r r a n g e | Overrange | Program mA output for display overrange |
| F u n c t i o n | Signal input conditioning | Select linear, square root, programmable exponent, or round horizontal tank function | U n d e r r a n g e | Underrange | Program mA output for display underrange |
| l i n e a r | Linear | Set meter for linear function and select number of linearization points | B r e a k | Break | Set input break condition operation |
| P V 1 | PV1 | Select PV1 number of linearization points | M a x i m u m | Maximum | Program maximum mA output allowed |
| P V 2 | PV2 | Select PV2 number of linearization points | M i n i m u m | Minimum | Program minimum mA output allowed |
| n o P o i n t s | Number of points | Set PV1 for 2 to 32-point linearization Set PV2 for 2 to 8-point linearization | C a l i b r a t e | Calibrate | Calibrate 4-20 mA output (internal reference source used for scaling the output) |
| S q u a r e r o o t | Square root | Set meter for square root extraction | 4 m A o u t p u t | 4 mA output | Enter mA output value read by milliamp meter with at least 0.001 mA resolution |

| Display | Parameter | Action/Setting | Display | Parameter | Action/Setting |
|---------|-----------------------------|--|---------|---------------------|--|
| 20 mA | 20 mA output | Enter mA output value read by milliamp meter with at least 0.001 mA resolution | [CAL] | Current calibration | Calibrate 4-20 mA current input (internal reference source used for scaling the input) |
| USER | User I/O | Assign function keys and digital I/O | [Lo] | Current low | Calibrate low current input (e.g. 4 mA) |
| F1 | F1 function key | Assign F1 function key | [Hi] | Current high | Calibrate high current input (e.g. 20 mA) |
| F2 | F2 function key | Assign F2 function key | u [CAL] | Voltage calibration | Calibrate voltage input |
| F3 | F3 function key | Assign F3 function key | u Lo | Voltage low | Calibrate low voltage input (e.g. 0 V) |
| F4 | F4 function | Assign F4 function (digital input) | u Hi | Voltage high | Calibrate high voltage input (e.g. 10 V) |
| d 1 1 | Digital input 1 | Assign digital input 1 – 8, if expansion modules are connected | d iRG | Diagnostics | Display parameter settings |
| d 0 1 | Digital output 1 | Assign digital output 1 – 8, if expansion modules are connected | LED t | LED test | Test all LEDs |
| iCAL | Internal source calibration | Enter internal source calibration (used for scaling the meter without a signal source) | Info | Information | Display software and S/N information |
| | | | ERASE | Erase | Erase MeterView Pro software stored in meter's memory |

Noise Filter (FILT)

The noise filter is available for unusually noisy signals that cause an unstable process variable display. The noise filter averages the input signal over a certain period. The filter level determines the length of time over which the signal is averaged. The filter level can be set between 2 and 199. The higher the filter level, the longer the averaging time and so the longer it takes the display to settle to its final value. Setting the filter level to zero disables the filter function.

Noise Filter Bypass (bypass)

The noise filter bypass changes the behavior of the meter so that small variations in the signal are filtered out but large abrupt changes in the input signal are displayed immediately. The bypass value determines the minimum amount of signal change to be displayed immediately. All signal changes smaller than the bypass value are filtered or averaged by the meter. The noise filter bypass may be set between 0.1 and 99.9% of full scale.

Rounding Feature (round)

The rounding feature is used to give the user a steadier display with fluctuating signals. Rounding is used in addition to the filter function.

Rounding causes the display to round to the nearest value according the rounding selected. See examples below:

| Rounding Selection | Actual Value | Display Value | Actual Value | Display Value |
|--------------------|--------------|---------------|--------------|---------------|
| 1 | 12.022 | 12.022 | 12.023 | 12.023 |
| 5 | 12.022 | 12.020 | 12.023 | 12.025 |
| 10 | 12.024 | 12.020 | 12.025 | 12.030 |

Modbus RTU Serial Communications (SEr ,RL)

The meter is equipped with serial communications capability as a standard feature using Modbus RTU Serial Communication Protocol.

The meter may be connected to a PC for initial configuration via the onboard micro USB connection. For ongoing digital communications with a computer or other data terminal equipment, an RS-232, or RS-485 option is required; see *Ordering Information* on page 5 for details.



Warning! Do not connect any equipment other than Precision Digital's expansion modules, cables, or meters to the RJ45 M-LINK connector. Otherwise damage will occur to the equipment and the meter.

Note: More detailed instructions are provided with each optional serial communications adapter.

Note: Refer to the ProVu® Modbus Register Tables located at www.predig.com for details.

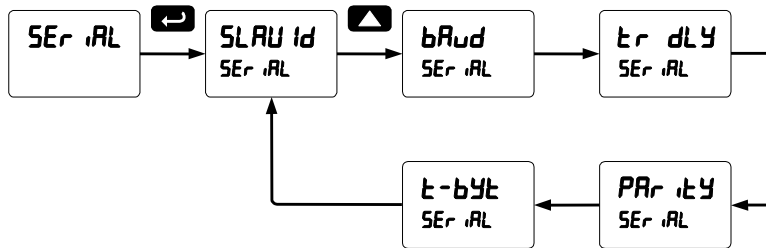

When using more than one meter in a multi-drop mode, each meter must be provided with its own unique address. The meter address (Slave ID) may be programmed between 1 and 247. The transmit delay may be set between 0 and 199 ms. The parity can be set to even, odd, or none with 1 or 2 stop bits.

Select Menu (SELEct)

The *Select* menu is used to select the signal input conditioner applied to the input (linear, square root, programmable exponent, or round horizontal tank), low-flow cutoff, and analog output programming. The multi-point linearization is part of the linear function selection.

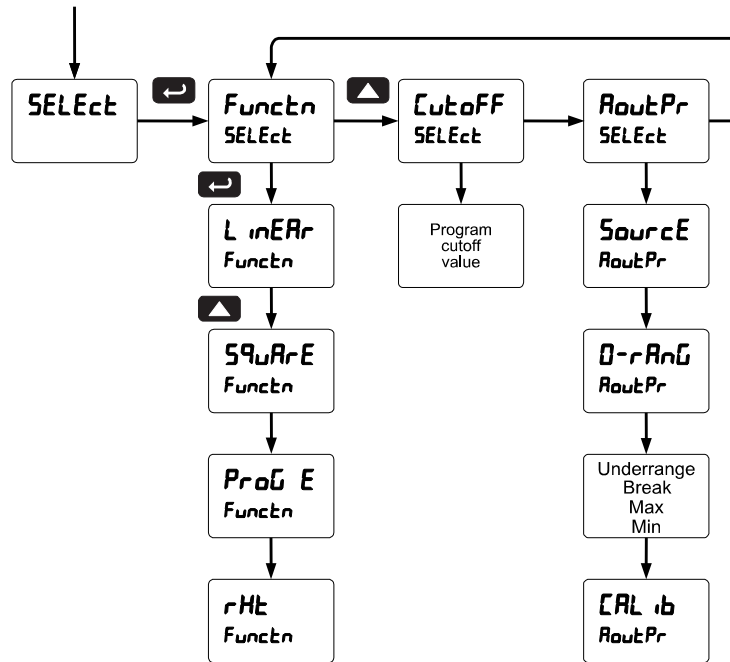

Signal Input Conditioning (Function)

The *Function* menu is used to select the signal input conditioner applied to the input: linear, square root, programmable exponent, or round horizontal tank volume calculation. The multi-point linearization is part of the linear function selection.

Meters are set up at the factory for linear function with 2-point linearization. The linear function provides a display that is linear with respect to the input signal.

Square Root Linearization (Square Root)

The square root function can be used to linearize the signal from a differential pressure transmitter and display flow rate in engineering units.

Programmable Exponent Linearization (Programmable Exponent)

The programmable exponent can be used to linearize the signal from level transmitters in open-channel flow applications using weirs and flumes.

Multi-Point Linearization (Linear)

Meters are set up at the factory for linear function with 2-point linearization. Up to 32 linearization points can be selected for PV1 under the linear function. The multi-point linearization can be used to linearize the display for non-linear signals such as those from level transmitters used to measure volume in odd-shaped tanks or to convert level to flow using weirs and flumes with complex exponent.

If the dual-scale level feature has been selected, the menus for PV1 & PV2 are enabled. PV2 can be programmed with up to 8 linearization points.

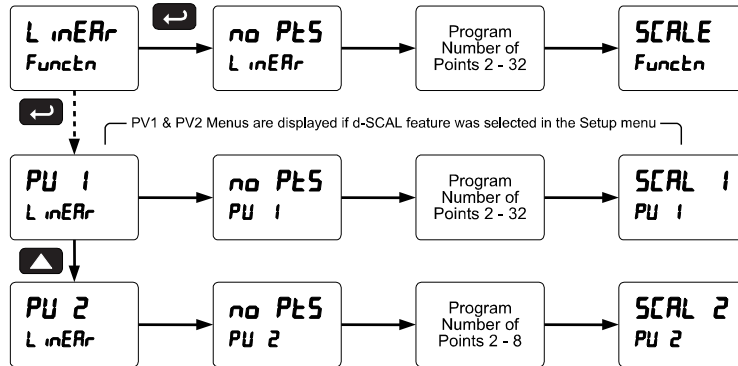

Round Horizontal Tank Linearization (Round Horizontal Tank)

This function automatically calculates the volume in a round horizontal tank with flat ends.

Set the display for the desired decimal point and engineering units before entering the round horizontal tank function. Select units, inches or cm for the tank dimensions. Enter the diameter and the length in inches and the results are calculated automatically in US gallons.

The meter can be scaled to display the volume in any engineering unit.

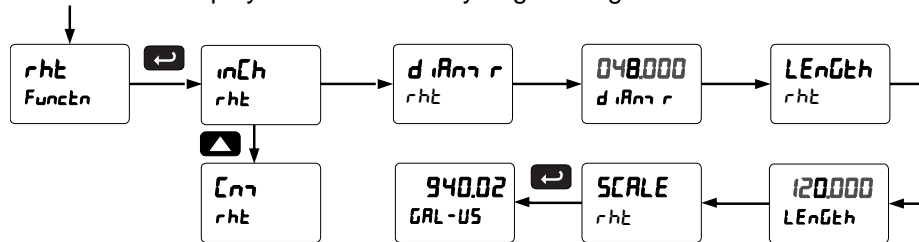

Note: After Scale is displayed continue pressing the Enter button until the meter completes the scaling of the input and display values.

Changing the Volume from Gallons to Liters

In the above graphic, entering the 48" for the diameter and 120" for the length of the round horizontal tank, the meter automatically calculates that the volume of the tank is 940.02 gallons.

1. Convert gallons to liters
 1 US gallon = 3.7854 L
 940.02 gal = 3558.4 L
2. Go to the *Setup* menu and change the decimal point to 1 decimal.
3. Go to the *Program – Scale* menu and press Enter until *d 1 2* is shown on the main display.
4. Press Enter and change the display 2 value to 3558.4.
5. The meter is now displaying the volume in liters.

Note: The display can be scaled to display the volume in any engineering units.

Low-Flow Cutoff (Cutoff)

The low-flow cutoff feature allows the meter to be programmed so that the often-unsteady output from a differential pressure transmitter, at low flow rates, always displays zero on the meter. The cutoff value may be programmed from 0 to 999999. The meter will display zero below the cutoff value. Programming the cutoff value to zero disables the cutoff feature.

Analog Output Programming (AoutPr)

The *Analog Output Programming* menu is used to program the behavior of the 4-20 mA output. The following parameters and functions are programmed in this menu:

1. Source: Source for generating the 4-20 mA output (e.g. PV)
2. Overrange: Analog output value with display in overrange condition
3. Underrange: Analog output value with display in underrange condition
4. Break: Analog output value when loop break is detected
5. Max: Maximum analog output value allowed regardless of input
6. Min: Minimum analog output value allowed regardless of input
7. Calibrate: Calibrate the internal 4-20 mA source reference used to scale the 4-20 mA output

Analog Output Source

The source for generating the 4-20 mA output may be assigned to the process variable, maximum or minimum value reached by the process, one of the set points, or the Modbus PV input.

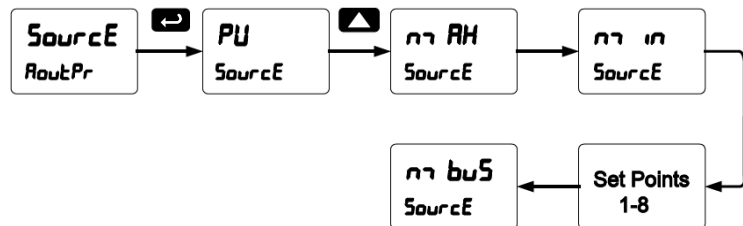

Analog Output Calibration

To perform the analog output calibration, it is recommended to use a milliamp meter with a resolution of at least 0.1 μ A to measure the output current. The values saved internally during this procedure are used for scaling the 4-20 mA output in the *Setup* menu.

Programmable Function Keys User Menu (uSEr)

The *User* menu allows the user to assign the front panel function keys F1, F2, and F3, the digital input F4 (a digital input located on the signal input connector), and up to eight additional digital inputs to access most of the menus or to activate certain functions immediately (e.g. reset max & min, hold relay states, etc.). This allows the meter to be greatly customized for use in specialized applications.

Up to eight digital outputs can be assigned to a number of actions and functions executed by the meter (i.e. alarms, relay acknowledgement, reset max, min, or max & min, tare, and reset tare). The digital outputs can be used to trigger external alarms or lights to indicate these specific events.

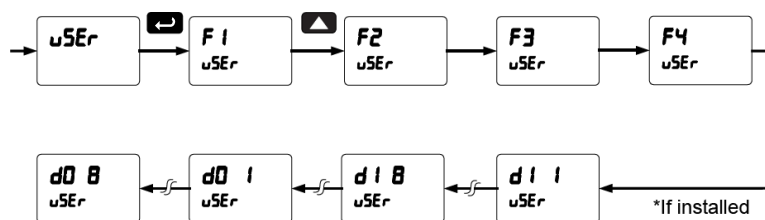

Function Keys & Digital I/O Available Settings

Refer to the following table for descriptions of each available function key or digital I/O setting.

| Display | Description | Display | Description |
|---------|---|----------|--|
| r5t H1 | Reset the stored maximum display value | Ln2 H1 | Display maximum display value on line 2 |
| r5t L0 | Reset the stored minimum display value | Ln2 L0 | Display minimum display value on line 2 |
| r5t HL | Reset the stored maximum & minimum display values | Ln2 HL | Display maximum & minimum display values on line 2 |
| tRrE | Capture tare and zero the display | F On 1* | Force relay 1 (*through 4) into the on state. This function is used in conjunction with a digital input expansion module to achieve interlock functionality. See page 35 for details about interlock relays. |
| r5t tr | Reset captured tare and resume normal operation | Control | Directly access the control menu |
| rELRY | Directly access the relay menu | dSRbL | Disable the selected function key or digital I/O |
| 5Et 1* | Directly access the set point menu for relay 1 (*through 8) | RcH | Acknowledge all active relays that are in a manual operation mode such as auto-manual or latching |
| rLY d | Disable all relays until a button assigned to <i>enable relays (rLY E)</i> is pressed | rE5Et | Directly access the reset menu |
| rLY E | Enable all relays to function as they have been programmed | nrEnu | Mimic the menu button functionality (digital inputs only) |
| 0 Hold | Hold current relay states as they are until a button assigned to <i>enable relays (rLY E)</i> is pressed | rGtE | Mimic the right arrow/F1 button functionality (digital inputs only) |
| d Hold | Hold the current display value momentarily while the function key or digital input is active. The process value will continue to be calculated in the background. | uP | Mimic the up arrow/F2 button functionality (digital inputs only) |
| Ln1 H1 | Display maximum display value on line 1 | EntEr | Mimic the enter/F3 button functionality (digital inputs only) |
| Ln1 L0 | Display minimum display value on line 1 | RLn r 1* | Provide indication when alarm 1 (*through 8) has been triggered (digital outputs only) |
| Ln1 HL | Display maximum & minimum display values on line 1 | | |

Tare (tRrE)

The tare function zero's out the display. In the case of scale weight, tare is used to eliminate container weight and provide net weight readings. There are two tare functions; Capture Tare and Reset Tare. When the capture tare function is used, the display reading is offset by the displayed amount to make the displayed value zero. This modified display value is the net value. The originally displayed value without the tare offset is the gross value. Both may be chosen as a display option.

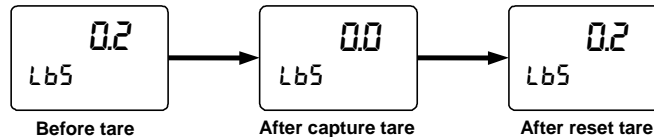

Reset tare removes the display offset of the net value, and the gross and net values become the same until a new capture tare is entered.

Internal Source Calibration (ICAL)

The meter is factory calibrated prior to shipment to read in milliamps and volts depending on the input selection. The calibration equipment is certified to NIST standards.

The use of calibrated signal sources is necessary to calibrate the internal source of the meter. The meter's internal source is what allows the user to scale the meter without applying a signal. Check calibration of the meter at least every 12 months. Each input must be recalibrated separately.

Notes:

1. If meter is in operation and it is intended to accept only one input type (e.g. 4-20 mA), recalibration of other input is not necessary.
2. Allow the meter to warm up for at least 15 minutes before performing the internal source calibration procedure.

The *Internal calibration* menu is part of the *Advanced Features* menu.

1. Press and hold the Menu button for three seconds to access the advanced features of the meter.
2. Press the Up arrow button to scroll to the *Internal calibration* menu (ICAL) and press Enter.
3. The meter displays either current calibration (I CAL) or voltage calibration (V CAL), according to the input setup. Press Enter to start the calibration process.

Example of Internal Calibration for current input:

4. The meter displays *low* input current message (I Lo). Apply the low input signal and press Enter. The display flashes for a moment while the meter is accepting the low input signal.
5. After the display stops flashing, a number is displayed with the leftmost digit brighter than the rest. The bright digit is the active digit that can be changed by pressing the Up arrow button. Press the Right arrow button to move to the next digit.
6. Set the display value to correspond to the input signal being calibrated, typically 4.000 mA.
7. The display moves to the *high* input calibration (I Hi). Apply the high input signal and press Enter.
8. Set the display for the high input calibration, in the same way as it was set for the low input calibration, typically 20.000 mA.

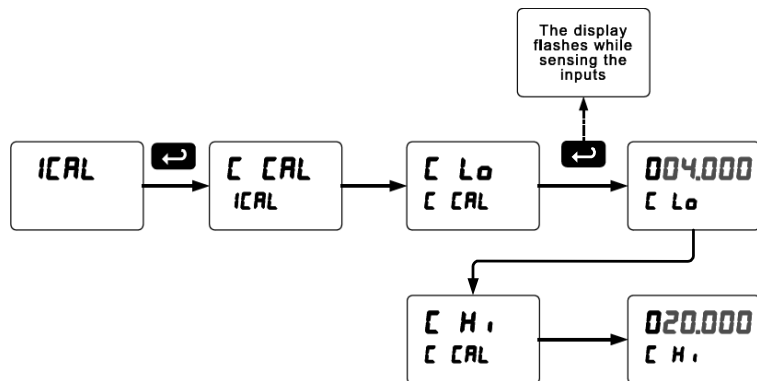

The graphic above shows the calibration of the current input. The voltage input is calibrated in a similar way.

Tips:

- Low and high input signals can be any valid values within the range of the meter.
- Observe minimum input span requirements between input 1 and input 2.
- Low input should be less than high input signal.

Error Message (Error)

An error message indicates that the calibration or scaling process was not successful.

The error message might be caused by any of the following conditions:

1. Input signal is not connected to the proper terminals, or it is connected backwards.
2. Wrong signal selection in *Setup* menu.
3. Minimum input span requirements not maintained.

Minimum Input Span

The minimum input span is the minimum difference between input 1 and input 2 signals required to complete the calibration or scaling of the meter.

| Input Range | Input 1 & Input 2 Span |
|-------------|------------------------|
| 4-20 mA | 0.15 mA |
| ±10 VDC | 0.01 VDC |

Meter Operation

The meter is capable of accepting current (0-20 mA, 4-20 mA) and voltage signals (0-5 V, 1-5 V, 0-10 V, ± 10 V) and displaying these signals in engineering units from -99999 to 999999 (e.g. a 4-20 mA signal could be displayed as -50.000 to 50.000).

The dual-line display can be customized by the user to operate in such a way as to satisfy a specific application. Typically, the main display is used for the process variable; while the second display is used for engineering units, custom legend, or set point indication.

The analog input can be scaled to display the process in two different scales; for example: with *d-SCAL* enabled, the main display could indicate level in feet and the second display could indicate the volume in gallons.

Additionally, the meter can be set up to display the analog input on the main display and the Modbus input on the second display. The relays and analog output can be programmed to operate from the Modbus PV input.

Front Panel Buttons Operation

| Button Symbol | Description |
|---------------|---|
| | Press to enter or exit Programming Mode, view settings, or exit max/min readings |
| | Press to reset max/min readings or other parameter/function assigned through the <i>User</i> menu |
| | Press to display max/min readings or other parameter/function assigned through the <i>User</i> menu |
| | Press to acknowledge relays or other parameters/function assigned through the <i>User</i> menu |

Function Keys Operation

During operation, the programmable function keys operate according to the way they have been programmed in the *Advanced Features – User* menu.

The table above shows the factory default settings for F1, F2, and F3.

F4 Operation

A digital input, F4, is standard on the meter. This digital input is programmed identically to function keys F1, F2, and F3. The input is triggered with a contact closure to COM, or with an active low signal. During operation, F4 operates according to the way it has been programmed in the *Advanced Features – User* menu.

Maximum/Minimum Readings

The max & min readings (peak & valley) reached by the process can be displayed either continuously or momentary:

1. Display briefly by assigning to the F1-F3 function keys or to the digital inputs in the *User* menu.
2. Display continuously by assigning either display to max/min through the *Display* menu.

Any of the F1-F3 function keys (buttons) and the digital inputs can be programmed to reset the max & min readings. The meters are set at the factory to display the max reading by pressing the Up arrow/F2 button and to use the Right arrow/F1 button to access the *Reset* menu.

To display max reading using function key with factory defaults:

1. Press Up arrow/F2 button to display maximum reading since the last reset/power-up.
2. To reset max/min press Right arrow/F1 button to access the *Reset* menu. The max & min displays are reset to actual values.
3. Press Menu to exit max/min display reading.

To display max/min readings continuously:

Assign either display to Max (*d H i*), Min (*d L o*), or toggle between Max and Min (*d HL*) every 10 seconds.

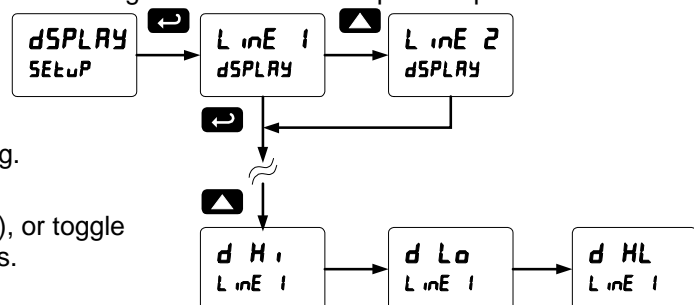

Troubleshooting

The rugged design and the user-friendly interface of the meter should make it unusual for the installer or operator to refer to this section of the manual. However, due to the many features and functions of the meter, it's possible that the setup of the meter does not agree with what an operator expects to see. If the meter is not working as expected, refer to the *Diagnostics* menu and recommendations below.

Diagnostics Menu (d ,RG)

The *Diagnostics* menu is located in the *Advanced Features* menu, to access *Diagnostics* menu see *Advanced Features Menu*, page 38.

This menu allows the user to test the functionality of all the meter LEDs, check the meter's software and version information, and erase the MeterView Pro software installation files from the meter. Press the Enter button to view the settings and the Menu button to exit at any time.

For a description of the diagnostic messages, see *Advanced Features Menu & Display Messages*, page 38.

Determining Software Version

To determine the software version of a meter:

1. Go to the *Diagnostics* menu (d ,RG) and press Enter button.
2. Press Up arrow button and scroll to Information menu (InFd).
3. Press Enter to access the software number (5Ft) and version (uEr) information. Write down the information as it is displayed. Continue pressing Enter until all the information is displayed.
4. The meter returns to Run Mode after displaying all the settings.

Reset Meter to Factory Defaults

When the parameters have been changed in a way that is difficult to determine what's happening, it might be better to start the setup process from the factory defaults.

Instructions to load factory defaults:

1. Enter the *Advanced Features* menu. See *Advanced Features Menu*, page 38.
2. Press Up arrow to go to *Diagnostics* menu
3. Press and hold Right arrow for three seconds, press Enter when display flashes rESEt.
Note: If Enter is not pressed within three seconds, the display returns to the *Diagnostics* menu.
4. The meter goes through an initialization sequence (similar as on power-up), and loads the factory default settings.

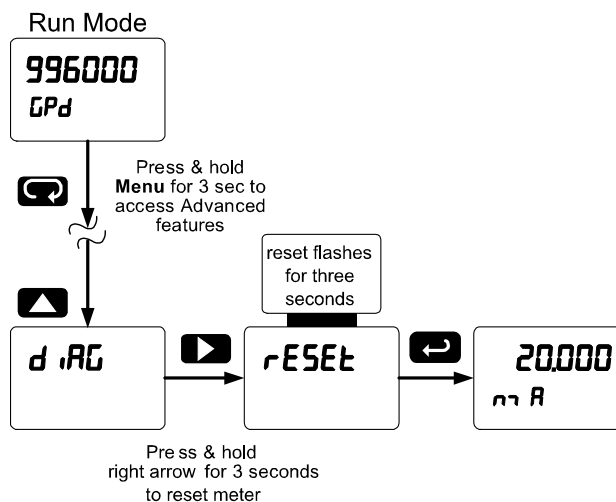

Note: The dual-scale selection for some level applications (d-SCAL) is not reset to the single scale factory default. This can be changed using the Setup – Input menu.

Factory Defaults & User Settings

The following table shows the factory setting for most of the programmable parameters on the meter.

| Parameter | Display | Default Setting |
|---------------------|----------|----------------------|
| Input type | inPut | 4-20 mA |
| Dual-scale feature | d-ScAL | No (Single scale) |
| Filter | FILtEr | 70 |
| Bypass | bYPAS | 0.2 |
| Function | FunctiOn | Linear |
| Number of points | no Pts | 2 |
| Programming | PrOG | Scale |
| Input 1 | inP 1 | 4.000 mA |
| Display 1 | d 15 1 | 4.000 |
| Input 2 | inP 2 | 20.000 mA |
| Display 2 | d 15 2 | 20.000 |
| Decimal point | dddd | 3 places |
| Cutoff value | CutOFF | 0.000 (disabled) |
| Display assignment | dSPLY | |
| Display Line 1 | L inE 1 | PV: Process variable |
| Display Line 2 | L inE 2 | Eng unit default= mA |
| Display intensity | d-IntY | 8 |
| Relay 1 action | Rct 1 | Automatic |
| Relay 1 set point | SEt 1 | 1.000 |
| Relay 1 reset point | rSEt 1 | 0.500 |
| Relay 2 action | Rct 2 | Automatic |
| Relay 2 set point | SEt 2 | 2.000 |
| Relay 2 reset point | rSEt 2 | 1.500 |
| Relay 3 action | Rct 3 | Automatic |
| Relay 3 set point | SEt 3 | 3.000 |
| Relay 3 reset point | rSEt 3 | 2.500 |
| Relay 4 action | Rct 4 | Automatic |
| Relay 4 set point | SEt 4 | 4.000 |
| Relay 4 reset point | rSEt 4 | 3.500 |
| Fail-safe relay 1 | FLS 1 | Off |
| Fail-safe relay 2 | FLS 2 | Off |
| Fail-safe relay 3 | FLS 3 | Off |
| Fail-safe relay 4 | FLS 4 | Off |
| On delay relay 1 | On 1 | 0.0 sec |
| Off delay relay 1 | OFF 1 | 0.0 sec |
| On delay relay 2 | On 2 | 0.0 sec |
| Off delay relay 2 | OFF 2 | 0.0 sec |
| On delay relay 3 | On 3 | 0.0 sec |

| Parameter | Display | Default Setting |
|----------------------|----------|--------------------|
| Off delay relay 3 | OFF 3 | 0.0 sec |
| On delay relay 4 | On 4 | 0.0 sec |
| Off delay relay 4 | OFF 4 | 0.0 sec |
| Loop break relay 1 | Lnbrk 1 | Ignore |
| Loop break relay 2 | Lnbrk 2 | Ignore |
| Loop break relay 3 | Lnbrk 3 | Ignore |
| Loop break relay 4 | Lnbrk 4 | Ignore |
| Display 1 analog out | d 15 1 | 4.000 |
| Output 1 value | Out 1 | 4.000 mA |
| Display 2 analog out | d 15 2 | 20.000 |
| Output 2 value | Out 2 | 20.000 mA |
| Source analog output | Source | Process Variable |
| Overrange output | OverRng | 21.000 mA |
| Underrange output | UnderRng | 3.000 mA |
| Loop break output | brkH | 1.000 mA |
| Maximum output | max | 23.000 mA |
| Minimum output | min | 1.000 mA |
| Slave ID (Address) | SLAVE ID | 247 |
| Baud rate | baud | 9600 |
| Transmit delay | tr dly | 50 ms |
| Parity | PRrty | Even |
| Byte-to-byte timeout | b-byt | 010 (0.1 sec) |
| F1 function key | F 1 | Reset max & min |
| F2 function key | F 2 | Line 1: Max (Hi) |
| F3 function key | F 3 | Acknowledge relays |
| F4 function | F 4 | Acknowledge relays |
| Digital input 1 | d i 1 | Menu |
| Digital input 2 | d i 2 | Right arrow |
| Digital input 3 | d i 3 | Up arrow |
| Digital input 4 | d i 4 | Enter |
| Digital output 1 | dO 1 | Alarm 1 |
| Digital output 2 | dO 2 | Alarm 2 |
| Digital output 3 | dO 3 | Alarm 3 |
| Digital output 4 | dO 4 | Alarm 4 |
| Password 1 | PR55 1 | 000000 (unlocked) |
| Password 2 | PR55 2 | 000000 (unlocked) |
| Password 3 | PR55 3 | 000000 (unlocked) |

Troubleshooting Tips

| Symptom | Check/Action |
|--|--|
| No display at all | Check power at power connector |
| Not able to change setup or programming, <code>L o c k</code> is displayed | Meter is password-protected, enter correct six-digit password to unlock |
| Meter displays error message during calibration (<code>E r r o r</code>) | Check: <ol style="list-style-type: none"> 1. Signal connections 2. Input selected in <i>Setup</i> menu 3. Minimum input span requirements |
| Meter displays <ol style="list-style-type: none"> 1. <code>999999</code> 2. <code>-999999</code> | Check: <ol style="list-style-type: none"> 1. Input selected in <i>Setup</i> menu 2. Corresponding signal at Signal connector |
| Display is unstable | Check: <ol style="list-style-type: none"> 1. Input signal stability and value 2. Display scaling vs. input signal 3. Filter and bypass values (increase) |
| Display response is too slow | Check filter and bypass values |
| Display reading is not accurate | Check: <ol style="list-style-type: none"> 1. Signal input conditioner selected: Linear, square root, etc. 2. Scaling or calibration |
| Display does not respond to input changes, reading a fixed number | Check: <ol style="list-style-type: none"> 1. Display assignment, it might be displaying max, min, or set point. |
| Display alternates between <ol style="list-style-type: none"> 1. <code>H i</code> and a number 2. <code>L o</code> and a number | Press Menu to exit max/min display readings. |
| Relay operation is reversed | Check: <ol style="list-style-type: none"> 1. Fail-safe in <i>Setup</i> menu 2. Wiring of relay contacts |
| Relay and status LED do not respond to signal | Check: <ol style="list-style-type: none"> 1. Relay action in <i>Setup</i> menu 2. Set and reset points |
| Flashing relay status LEDs | Relays in manual control mode or relay interlock switches opened. |
| Meter not communicating with application programs | Check: <ol style="list-style-type: none"> 1. Serial adapter and cable 2. Serial settings 3. Meter address and baud rate |
| If the display locks up or the meter does not respond at all | Cycle the power to reboot the microprocessor. |
| Other symptoms not described above | Call Technical Support for assistance. |

Note: Certain sequences of events can cause unexpected results. To solve these issues, it is best to start fresh from factory defaults and map changes ahead of time, rather than at random.



EU Declaration of Conformity

Issued in accordance with ISO/IEC 17050-1:2004.

We,

**Precision Digital Corporation
233 South Street
Hopkinton, MA 01748 USA**

as the manufacturer, declare under our sole responsibility that the product(s),

Model PD6000 ProVu Series Process Meter

to which this declaration relates, is in conformity with the European Union Directives shown below:

| | |
|-------------------|------------------------------|
| 2014/35/EU | Low Voltage Directive |
| 2014/30/EU | EMC Directive |
| 2011/65/EU | RoHS Directive |

This conformity is based on compliance with the application of harmonized or applicable technical standards and, when applicable or required, a European Union notified body certification.

Standards:

EN 55022:2003
EN 61000-6-2:2001
EN 61010-1:2001
EN 61326:2006

The standards EN 55022:2003, EN 61000-6-2:2001, EN 61010-1:2001, and EN 61326:2006 are no longer harmonized. The requirements of these standards have been checked against the harmonized standards EN 55022:2010, EN 61000-6-2:2005, EN 61010-1:2010, and EN 61326:2013 and there were no major technical changes affecting the latest technical knowledge for the products listed above.

Product Markings:



Signed for and on behalf of Precision Digital Corporation:



Name: Jeffrey Peters
Company: Precision Digital Corporation
Title: President
Date: 04/20/2016

Document No: DoC PD6000 {042016}

How to Contact Precision Digital

- For Technical Support please
Call: (800) 610-5239 or (508) 655-7300
Fax: (508) 655-8990
Email: support@predig.com
- For Sales Support or to place an order please
contact your local distributor or
Call: (800) 343-1001 or (508) 655-7300
Fax: (508) 655-8990
Email: sales@predig.com
- For the latest version of this manual please visit
www.predig.com

PRECISION DIGITAL CORPORATION

233 South Street • Hopkinton MA 01748 USA
Tel (800) 343-1001 • Fax (508) 655-8990



www.predig.com